

# Wi-Fi Video Doorbell

## User Manual

### About this Manual

The Manual includes instructions for using and managing the product. Pictures, charts, images and all other information hereinafter are for description and explanation only. The information contained in the Manual is subject to change, without notice, due to firmware updates or other reasons. Please find the latest version in the company website .  
Visit the company website to get the manuals, client software, and developing tools.  
Please use this user manual under the guidance of professionals.

### Trademarks Acknowledgement

The trademarks and logos mentioned below are the properties of their respective owners.

### Legal Disclaimer

TO THE MAXIMUM EXTENT PERMITTED BY APPLICABLE LAW, THE PRODUCT DESCRIBED, WITH ITS HARDWARE, SOFTWARE AND FIRMWARE, IS PROVIDED "AS IS", WITH ALL FAULTS AND ERRORS, AND MAKES NO WARRANTIES, EXPRESS OR IMPLIED, INCLUDING WITHOUT LIMITATION, MERCHANTABILITY, SATISFACTORY QUALITY, FITNESS FOR A PARTICULAR PURPOSE, AND NON-INFRINGEMENT OF THIRD PARTY. IN NO EVENT WILL DIRECTORS, OFFICERS, EMPLOYEES, OR AGENTS BE LIABLE TO YOU FOR ANY SPECIAL, CONSEQUENTIAL, INCIDENTAL, OR INDIRECT DAMAGES, INCLUDING, AMONG OTHERS, DAMAGES FOR LOSS OF BUSINESS PROFITS, BUSINESS INTERRUPTION, OR LOSS OF DATA OR DOCUMENTATION, IN CONNECTION WITH THE USE OF THIS PRODUCT, EVEN IF WE HAS BEEN ADVISED OF THE POSSIBILITY OF SUCH DAMAGES.

REGARDING TO THE PRODUCT WITH INTERNET ACCESS, THE USE OF PRODUCT SHALL BE WHOLLY AT YOUR OWN RISKS. WE SHALL NOT TAKE ANY RESPONSIBILITIES FOR ABNORMAL OPERATION, PRIVACY LEAKAGE OR OTHER DAMAGES RESULTING FROM CYBER ATTACK, HACKER ATTACK, VIRUS INSPECTION, OR OTHER INTERNET SECURITY RISKS; HOWEVER, WE WILL PROVIDE TIMELY TECHNICAL SUPPORT IF REQUIRED.

SURVEILLANCE LAWS VARY BY JURISDICTION. PLEASE CHECK ALL RELEVANT LAWS IN YOUR JURISDICTION BEFORE USING THIS PRODUCT IN ORDER TO ENSURE THAT YOUR USE CONFORMS THE APPLICABLE LAW. WE SHALL NOT BE LIABLE IN THE EVENT THAT THIS PRODUCT IS USED WITH ILLEGITIMATE PURPOSES.

IN THE EVENT OF ANY CONFLICTS BETWEEN THIS MANUAL AND THE APPLICABLE LAW, THE LATER PREVAILS.

### Regulatory Information

FCC Information  
Please take attention that changes or modification not expressly approved by the party responsible for compliance could void the user's authority to operate the equipment.

FCC compliance: This equipment has been tested and found to comply with the limits for a Class B digital device, pursuant to part 15 of the FCC Rules. These limits are designed to provide reasonable protection against harmful interference in a residential installation. This equipment generates, uses and can radiate radio frequency energy and, if not installed and used in accordance with the instructions, may cause harmful interference to radio communications. However, there is no guarantee that interference will not occur in a particular installation. If this equipment does cause harmful interference to radio or television reception, which can be determined by turning the equipment off and on, the user is encouraged to try to correct the interference by one or more of the following measures:  
—Reorient or relocate the receiving antenna.  
—Increase the separation between the equipment and receiver.  
—Connect the equipment into an outlet on a circuit different from that to which the receiver is connected.  
—Consult the dealer or an experienced radio/TV technician for help.

This equipment should be installed and operated with a minimum distance 20cm between the radiator and your body.  
FCC Conditions  
This device complies with part 15 of the FCC Rules. Operation is subject to the following two conditions:  
1. This device may not cause harmful interference.  
2. This device must accept any interference received, including interference that may cause undesired operation.

### EU Conformity Statement

This product and - if applicable - the supplied accessories too are marked with "CE" and comply therefore with the applicable harmonized European standards listed under the EMC Directive 2014/30/EU, the RoHS Directive 2011/65/EU.



2012/19/EU (WEEE directive): Products marked with this symbol cannot be disposed of as unsorted municipal waste in the European Union. For proper recycling, return this product to your local supplier upon the purchase of equivalent new equipment, or dispose of it at designated collection points. For more information see: [www.recyclethis.info](http://www.recyclethis.info)



2006/66/EC (battery directive): This product contains a battery that cannot be disposed of as unsorted municipal waste in the European Union. See the product documentation for specific battery information. The battery is marked with this symbol, which may include lettering to indicate cadmium (Cd), lead (Pb), or mercury (Hg). For proper recycling, return the battery to your supplier or to a designated collection point. For more information see: [www.recyclethis.info](http://www.recyclethis.info)

Industry Canada ICES-003 Compliance  
This device meets the CAN ICES-3 (B)/NMB-3(B) standards requirements.

This device complies with Industry Canada licence-exempt RSS standard(s). Operation is subject to the following two conditions:  
(1) this device may not cause interference, and  
(2) this device must accept any interference, including interference that may cause undesired operation of the device.

Le présent appareil est conforme aux CNR d'Industrie Canada applicables aux appareils radioexempts de licence. L'exploitation est autorisée aux deux conditions suivantes :

(1) l'appareil ne doit pas produire de brouillage, et  
(2) l'utilisateur de l'appareil doit accepter tout brouillage radioélectrique subi, même si le brouillage est susceptible d'en compromettre le fonctionnement.

Under Industry Canada regulations, this radio transmitter may only operate using an antenna of a type and maximum (or lesser) gain approved for the transmitter by Industry Canada. To reduce potential radio interference to other users, the antenna type and its gain should be so chosen that the equivalent isotropically radiated power (e.i.r.p.) is not more than that necessary for successful communication.  
Conformément à la réglementation d'Industrie Canada, le présent émetteur radio peut fonctionner avec une antenne d'un type et d'un gain maximal (ou inférieur) approuvé pour l'émetteur par Industrie Canada. Dans le but de réduire les risques de brouillage radioélectrique à l'intention des autres utilisateurs, il faut choisir le type d'antenne et son gain de sorte que la

puissance isotrope rayonnée équivalente (p.i.r.e.) ne dépasse pas l'intensité nécessaire à l'établissement d'une communication satisfaisante.  
This equipment should be installed and operated with a minimum distance 20cm between the radiator and your body.  
Cet équipement doit être installé et utilisé à une distance minimale de 20 cm entre le radiateur et votre corps.

### Symbol Conventions

The symbols that may be found in this document are defined as follows.

**NOTE**  
Provides additional information to emphasize or supplement important points of the main text.

**WARNING**  
Indicates a potentially hazardous situation, which if not avoided, could result in equipment damage, data loss, performance degradation, or unexpected results.

**DANGER**  
Indicates a hazard with a high level of risk, which if not avoided, will result in death or serious injury.

**WARNING**  
● The working temperature of the device is from -30° C to 50° C.  
● All the electronic operation should be strictly compliance with the electrical safety regulations, fire prevention regulations and other related regulations in your local region.  
● Please use the power adapter, which is provided by normal company. The power consumption cannot be less than the required value.  
● Do not connect several devices to one power adapter as adapter overload may cause over-heat or fire hazard.

● Please make sure that the power has been disconnected before you wire, install or dismantle the device.  
● When the product is installed on wall, the device shall be firmly fixed.  
● If smoke, odors or noise rise from the device, turn off the power at once and unplug the power cable, and then please contact the service center.  
● If the product does not work properly, please contact your dealer or the nearest service center. Never attempt to disassemble the device yourself. (We shall not assume any responsibility for problems caused by unauthorized repair or maintenance.)

Make sure the power voltage across the doorbell should be between 16 VAC and 24 VAC.

**WARNING**  
● Do not drop the device or subject it to physical shock, and do not expose it to high electromagnetic radiation. Avoid the equipment installation on vibrations surface or places subject to shock (ignorance can cause equipment damage).  
● Do not place the device in extremely hot (refer to the specification of the device for the detailed operating temperature), cold, dusty or damp locations, and do not expose it to high electromagnetic radiation.  
● The device cover shall be kept from rain and moisture.  
● Exposing the equipment to direct sun light, low ventilation or heat source such as heater or radiator is forbidden (ignorance can cause fire danger).  
● Do not aim the device at the sun or extra bright places. A blooming or smear may occur otherwise (which is not a malfunction however), and affecting the endurance of sensor at the same time.  
● Please use the provided glove when open up the device cover, avoid direct contact with the device cover, because the acidic sweat of the fingers may erode the surface coating of the device cover.  
● Please use a soft and dry cloth when clean inside and outside surfaces of the device cover, do not use alkaline detergents.  
● Please keep all wrappers after unpack them for future use. In case of any failure occurred, you need to return the device to the factory with the original wrapper. Transportation without the original wrapper may result in damage on the device and lead to additional costs.  
● Please connect a resistor (included in the box content) to the doorbell if no electrical chime or mechanical chime is connected.

(16 VAC to 24 VAC)

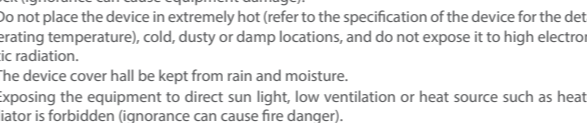

### NOTE

Make sure the power voltage across the doorbell should be between 16 VAC and 24 VAC.

### Appearance

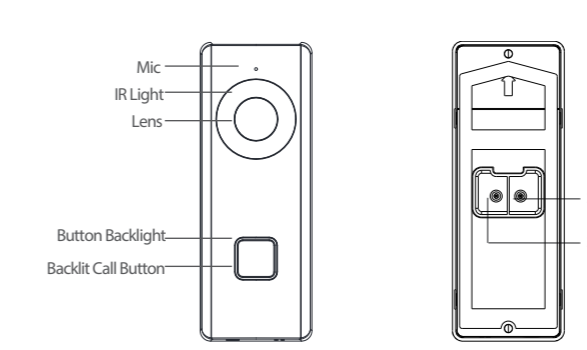

Name	Description
------	-------------

- IR Light** Auto light source for night vision. The lights are behind the panel.
- Solid blue: The doorbell is starting up and running properly.
  - Cycling blue and red: Wi-Fi is not connected.
  - Flashing red: The doorbell is upgrading.
  - Flashing blue: The doorbell is calling the App.
  - No backlight: The doorbell is speaking with the App.
- Button Backlight**

**Screw 1&2** These 2 screws are used to connect the power cables.

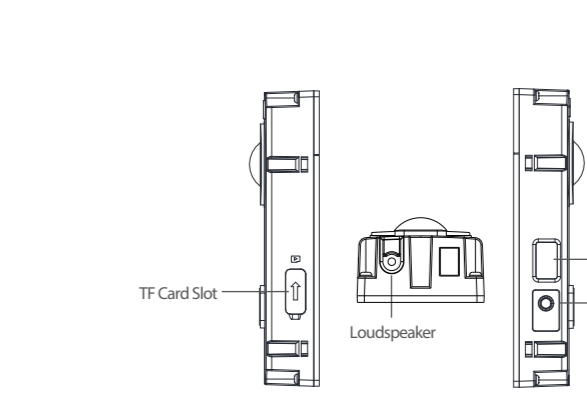

Name	Description
------	-------------

- TF Card Slot** For TF card. If a TF card is used, video files will be stored in the TF card.
- RESET Button** If the doorbell has not been activated, hold the button for 5 seconds to enter the Wi-Fi connection mode. The call backlight cycles blue and red.
- NOTE** If you do no operation in 3 minutes the doorbell will exit the Wi-Fi configuration automatically.
- If the doorbell has been activated, hold the button for 15 seconds to restore the factory settings.

### Installation

#### Step 1 (Optional) Install the TF card.

Remove the card slot cover, and insert the TF card into the card slot on the side of the doorbell.



**NOTE**  
Motion detection does not support recording without the TF card.

#### Step 2 Attach the mounting template.

- Align the cable hole on the mounting template with the cable hole on the wall.
- Attach the mounting template on the wall.

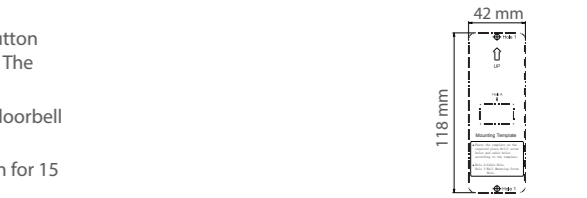

### Step 3 Connect the power cables.



- Make sure you have powered off the main power switch of your home.
- Connect a resistor (included in the box content) to the doorbell if no electrical chime or mechanical chime is connected.

- Loosen the screws on the rear panel of the doorbell, put loops of power cables (included in the box content) into the screws, and then tighten.
- Pull the power cables from the wall, and connect to the power connector.
- Connect the power cables to the power connector (included in the box content).

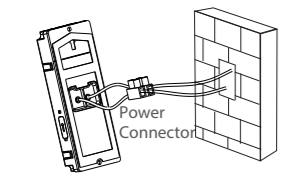
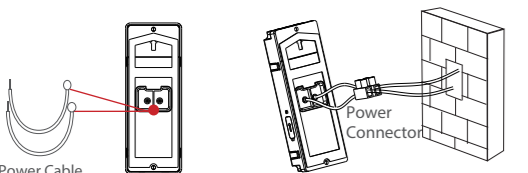

Power Cable

Power Connector

### Step 4 Install the doorbell.



The suggested installation distance is only for your reference.

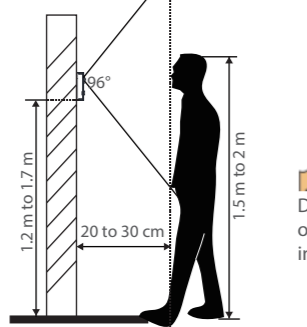

- Drill 2 holes on the wall according to the mounting template. Insert the expansion tubes into the drilled holes.

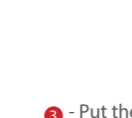

Expansion Tube

- Route the cables and insert cables and power connector into the wall. Align the screw holes on the doorbell body with the drilled holes on the wall. Fix the doorbell body to the wall tightly with 2 screws.

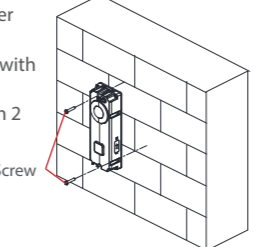

Screw

- Put the faceplate to cover the doorbell body. Use 1 set screw to fix the faceplate with the doorbell body tightly.

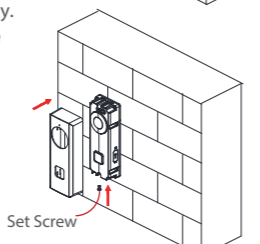

Set Screw

Do not grate your nails or other objects on the lens's glass when installing the doorbell.

## Getting Started

### Step 1 Power on the doorbell.

Make sure you have connected the power cables for the doorbell. Power on the main power switch of your home. When the blue light is on, the doorbell is powered on.

### Step 2 Set the LTS-Connect App.

- Install LTS-Connect App and register a user account. Connect your mobile device to Wi-Fi. Download and install the LTS-Connect App by searching "LTS-Connect" in App store or Google Play™.



- Launch the App and register for a LTS-Connect user account.
- Log in to the LTS-Connect App. Connect your mobile device to Wi-Fi. Start the LTS-Connect App, and input the LTS-Connect user account to log in to the App.

### Step 3 Activate the doorbell and add it to the LTS-Connect App.

- Scan QR code or input the serial No. of the doorbell. In the Home page of the LTS-Connect App, tap "+" on the upper-right corner to add the doorbell. Scan the QR code or input the serial No. on the front panel of the doorbell body.

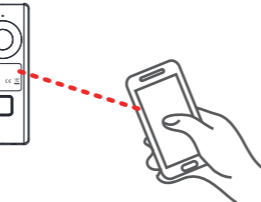

- Connect Wi-Fi.

The doorbell supports 3 kinds of Wi-Fi mode: 802.11 b only, 802.11 g only, and 802.11 bg only.

- The network connection page will pop up after scanning the QR code of the doorbell successfully.
- Tap **Connect to a Network**.
  - Choose Wireless Connection to set the Wi-Fi connection.

- Input the Wi-Fi password that your mobile phone has connected to.
- Hold the reset button for 5 seconds.
- After hearing the voice prompt "Start configuring Wi-Fi.", tap **Next** in 3 minutes to start the Wi-Fi connection.

- Activate the doorbell. The activation page will pop up after finishing the Wi-Fi connection. Tap **Set Device Password** and input a password to activate the doorbell.

- Link the LTS-Connect account. Input the verification code of the doorbell in the pop-up page after activation.

This step is only necessary for adding the doorbell by inputting the serial No.

- Tap **OK** to finish adding the doorbell to the LTS-Connect account.

## Operating Doorbell

Via the LTS-Connect App, you can realize some certain functions of the doorbell (including, but not limited to, live view, and remote playback).

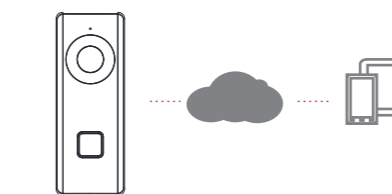

**Video Intercom**  
Press **Call Button** on the doorbell. You can accept the call via the LTS-Connect App, get the live view of the doorbell, and capture the snapshots.

**Live View**  
Launch the LTS-Connect App and you can get the live view of the connected

**Playback**  
Launch the LTS-Connect App, tap a connected device and tap **Gallery** to play back.

**Recording**

- Check the TF card status by tapping **Storage Status** in the Device Settings page.
- If the TF card status displays as **Uninitialized**, tap to initialize it. The status will then change to **Normal**. You can then start recording any event triggered video in the camera of the doorbell such as motion detection

**Alarm Notification**  
Launch the LTS-Connect App and tap **Message** to see the alarm messages, such as motion detection alarm message.

- Note**
- The messages will be pushed automatically by enabling **Message Push Notification**.
  - The App can receive the triggered alarm automatically when the doorbell is powered on by enabling **Auto-Receive Alarm after Powering on**.