

HD-TVI Speed Dome

Installation Manual

Thank you for purchasing our product. If there is any question or request, please do not hesitate to contact the dealer.

This manual is applicable to **HD-TVI Speed Domes**.

This manual may contain several technically inaccurate points or printing errors, and the content is subject to change without notice. The updates will be added into the new version of this manual. We will readily improve or update the products or procedures described in the manual.

Regulatory Information

FCC Information

FCC compliance: This equipment has been tested and found to comply with the limits for a digital device, pursuant to part 15 of the FCC Rules. These limits are designed to provide reasonable protection against harmful interference when the equipment is operated in a commercial environment. This equipment generates, uses, and can radiate radio frequency energy and, if not installed and used in accordance with the instruction manual, may cause harmful interference to radio communications. Operation of this equipment in a residential area is likely to cause harmful interference in which case the user will be required to correct the interference at his own expense.

FCC Conditions

This device complies with part 15 of the FCC Rules. Operation is subject to the following two conditions:

1. This device may not cause harmful interference.
2. This device must accept any interference received, including interference that may cause undesired operation.

EU Conformity Statement



This product and - if applicable - the supplied accessories too are marked with "CE" and comply therefore with the applicable harmonized European standards listed under the Low Voltage Directive 2006/95/EC, the EMC Directive 2004/108/EC, the RoHS Directive 2011/65/EU.



2012/19/EU (WEEE directive): Products marked with this symbol cannot be disposed of as unsorted municipal waste in the European Union. For proper recycling, return this product to your local supplier upon the purchase of equivalent new equipment, or dispose of it at designated collection points. For more information, see: www.recyclethis.info.





2006/66/EC (battery directive): This product contains a battery that cannot be disposed of as unsorted municipal waste in the European Union. See the product documentation for specific battery information. The battery is marked with this symbol, which may include lettering to indicate cadmium (Cd), lead (Pb), or mercury (Hg). For proper recycling, return the battery to your supplier or to a designated collection point. For more information, see: www.recyclethis.info.

Safety Instruction

These instructions are intended to ensure that user can use the product correctly to avoid danger or property loss. The precaution measure is divided into **Warnings** and **Cautions**:

Warnings: Neglecting any of the warnings may cause serious injury or death.

Cautions: Neglecting any of the cautions may cause injury or equipment damage.

	
<p>Warnings:</p> <p>Follow these safeguards to prevent serious injury or death.</p>	<p>Cautions:</p> <p>Follow these precautions to prevent potential injury or material damage.</p>



Warnings

- In the use of the product, you must be strict compliance with the electrical safety regulations of the nation and region.
- Please use the power adapter, which is provided by normal company. Refer to the specification manual for the standard of power adapter and the power consumption cannot be less than the required value.
- Do not connect several devices to one power adapter as adapter overload may cause over-heat or fire hazard.
- Please make sure that the plug is firmly connected on the power socket.
- When the product is installed on wall or ceiling, the device shall be firmly fixed.
- If smoke, odors or noise rise from the device, turn off the power at once and unplug the power cable, and then please contact the service center.
- If the product does not work properly, please contact your dealer or the nearest service center. Never attempt to disassemble the camera yourself. (We shall not assume any responsibility for problems caused by unauthorized repair or maintenance.)



Cautions

- Do not drop the dome or subject it to physical shock, and do not expose it to high electromagnetism radiation. Avoid the equipment installation on vibrations surface or places subject to shock (ignorance can cause equipment damage).
- Do not place the dome in extremely hot, cold, dusty or damp locations, otherwise fire or electrical shock will occur. For operating temperature, please refer to the specification manual for details.
- The dome cover for indoor use shall be kept from rain and moisture.
- Exposing the equipment to direct sun light, low ventilation or heat source such as heater or radiator is forbidden (ignorance can cause fire danger).
- Do not aim the camera at the sun or extra bright places. A blooming or smear may occur

otherwise (which is not a malfunction however), and affecting the endurance of sensor at the same time.

- Please use the provided glove when open up the dome cover, avoid direct contact with the dome cover, because the acidic sweat of the fingers may erode the surface coating of the dome cover.
- Please use a soft and dry cloth when clean inside and outside surfaces of the dome cover, do not use alkaline detergents.

Table of Contents

Chapter 1	Preparation	1
Chapter 2	Installation	2
2.1	Cable Descriptions	2
2.2	DIP Switch Settings	4
2.2.1	5-inch Speed Dome Settings	4
2.2.2	5-inch IR Speed Dome Settings	5
2.2.3	7-inch IR Speed Dome Settings	8
2.2.4	Mini Speed Dome Settings	10
2.3	Wiring and Installation	12
2.3.1	Wiring	12
2.3.2	Installing the Bracket	13
2.3.3	Setting the DIP Switch	14
2.3.4	Installing the Speed Dome	14
Chapter 3	In-door Mounting Applications	16
3.1	5-inch Speed Dome In-ceiling Mounting Applications	16
3.2	5-inch Speed Dome Ceiling Mounting Applications	18
3.2.1	Removing the Mounting Bracket	18
3.2.2	Wiring	20
3.2.3	Ceiling Mounting	20
3.3	Mini Speed Dome In-ceiling Mounting Applications	22
3.3.1	Mini Analog Speed Dome In-ceiling Mounting	22
3.3.2	Mini IR Speed Dome In-ceiling Mounting	24
3.4	Mini Speed Dome Ceiling Mounting Applications	26
3.4.1	Wiring	26
3.4.2	Ceiling Mounting	26
Appendix		29
Appendix 1	Lightning & Surge Protection	29
Appendix 2	RS485 Bus Connection	30
Appendix 3	24VAC Wire Gauge & Transmission Distance	33
Appendix 4	Wire Gauge Standards	34

Chapter 1 Preparation

Basic Requirement

- All the electronic operation should be strictly compliance with the electrical safety regulations, fire prevention regulations and other related regulations in your local region.
- Check the package contents and make sure that the device in the package is in good condition and all the assembly parts are included.

Checking Installing Environment

- Be sure that there is enough space to install the speed dome and accessories.
- Make sure that the wall is strong enough to withstand at least 8 times the weight of the dome and the bracket.

Preparing Cables

Choose the video cable according to the transmission distance, the minimum requirement for the coaxial video cable are shown as follows:

- 75Ω impedance;
- 100% copper core conducting wire;
- 95% weaving copper shield;
- RS485 communication cable, please refer to Appendix 2.
- 24V AC power cable, please refer to Appendix 3

Preparing Tools

Before installation, please prepare the tools needed, such as the expansion screws, electric hammer, electric drill, wrench, screwdriver, electroprobe and network cable.

Original Packaging

When you unpack the dome, please keep the original package properly, in case of returning or repairing the camera, you can pack the dome with the package.



The user should be responsible for any damage caused when transporting with unoriginal package.

Chapter 2 Installation

Before you start:

Check the package contents and make sure that the device in the package is in good condition and all the assembly parts are included.

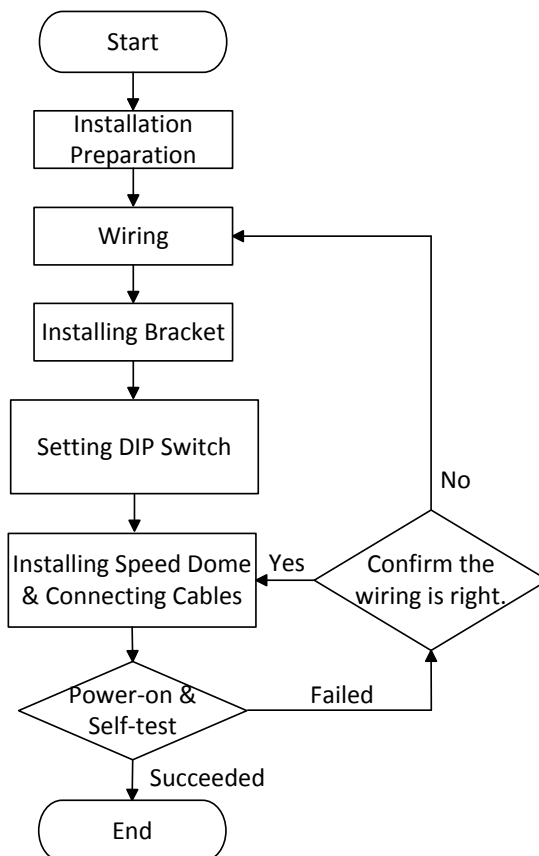

Figure 2-1 Installation Flow Diagram

2.1 Cable Descriptions

Please turn the power off before connect the cables.

The cable interfaces of HD-TVI speed dome are shown in Figure 2-2. The cables of RS-485, power supply, etc. are distinguished by different colors. Please refer to the labels attached on the cables for identification.

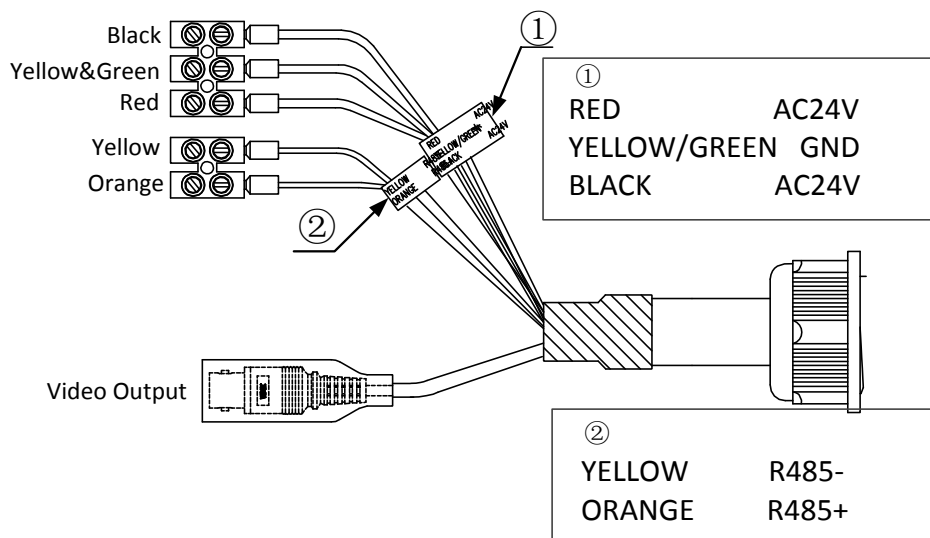

Figure 2-2 Cables of 7-inch IR Speed Dome

Name	Description
AC24V	Power supply
RS485+/-	485 control
VIDEO	Coaxial and analog video output

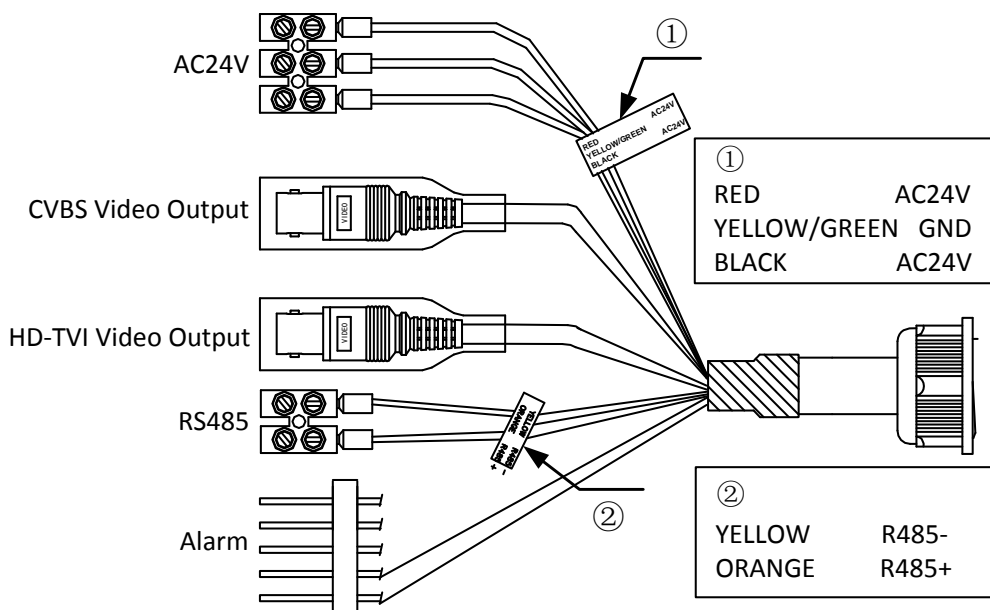

Figure 2-3 Cables of Other Speed Domes

Name	Description
AC24V	Power supply
RS485+/-	485 control
CVBS VIDEO	SD analog video output
HD-TVI VIDEO	HD-TVI and coaxial video output
ALARM	2-ch alarm inputs and 1-ch alarm output

2.2 DIP Switch Settings

2.2.1 5-inch Speed Dome Settings

The DIP switch is used for setting the address and baudrate for the speed dome, with value ON=1 and OFF=0.

The SW1 switches from the first to the eighth are used to set the address. The SW2 switches are used to set the baudrate.



- The default dome address is 0. The default baudrate is 2400.
- The speed dome is self-adaptive to the Pelco-P, Pelco-D and Private-Code. You do not have to set the RS-485 control protocol by the DIP switch.

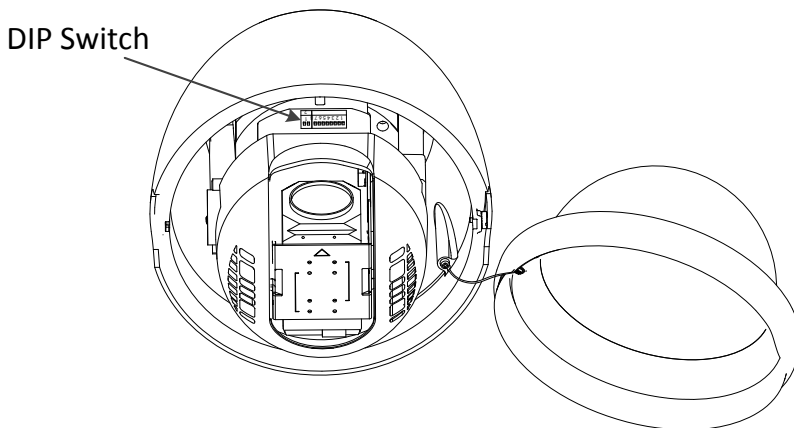

Figure 2-4 DIP Switch Settings for 5-inch Outdoor Speed Dome

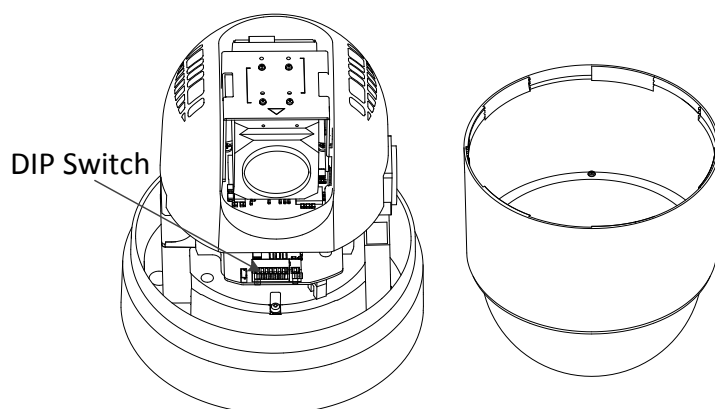

Figure 2-5 DIP Switch Settings for 5-inch Indoor Speed Dome

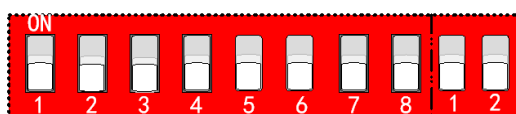

Figure 2-6 Enlarged View of DIP Switch

◆ Address Settings

The SW1-switches from 1 to 8 are used for setting the address of speed dome. You can refer to Table 2-1 for details of setting the speed dome address to a specific number.

Table 2-1 Set the Dome Address between 0 and 255

Switch No. Dome Address	1	2	3	4	5	6	7	8
0	OFF	OFF	OFF	OFF	OFF	OFF	OFF	OFF
1	ON	OFF	OFF	OFF	OFF	OFF	OFF	OFF
2	OFF	ON	OFF	OFF	OFF	OFF	OFF	OFF
3	ON	ON	OFF	OFF	OFF	OFF	OFF	OFF
...
255	ON	ON	ON	ON	ON	ON	ON	ON

◆ Baudrate Settings

The number 1 and 2 SW2-switches are used for setting the baudrate of the speed dome. The baudrate can be 2400bps, 4800bps, 9600bps and 19200bps. The baudrate will be set as 2400bps by default if it is out of this range. Refer to the following table:

Table 2-2 Set the Baudrate of the Dome

Switch No. Baudrate	1	2
2400	OFF	OFF
4800	ON	OFF
9600	OFF	ON
19200	ON	ON

2.2.2 5-inch IR Speed Dome Settings

The DIP switch is for setting the speed dome address, baudrate, protocol, etc., with value ON=1 and OFF=0. The switch label is on the back of the SWITCH cover as shown in Figure 2-7.

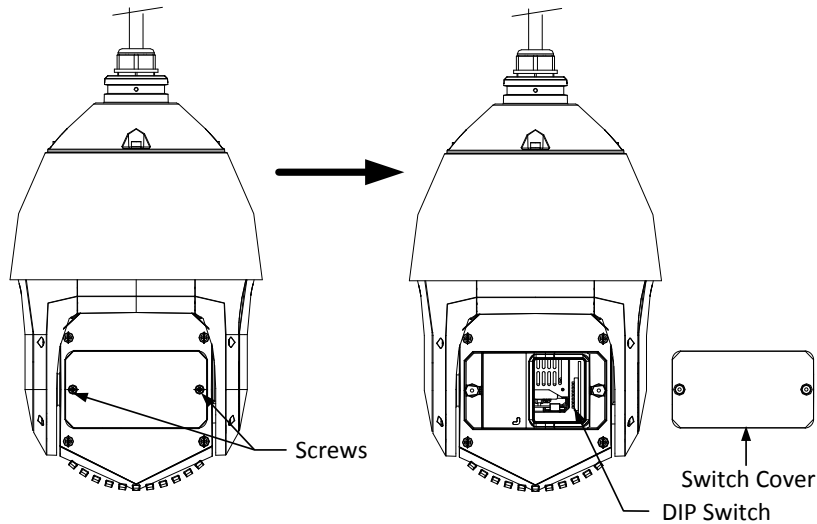

Figure 2-7 Position of DIP Switch for 5-inch IR Speed Dome

● Setting DIP Switch

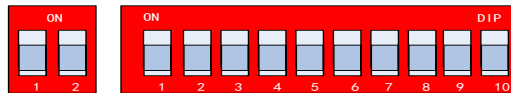

Figure 2-8 Enlarged View of DIP Switch



- For some certain models, the two individual DIP switches at the left side of the Figure 2-8 are supported for turning on/off the terminator; while other models are not supported.
- The default dome address is 0; the default baudrate is 2400; and the default value of the 120Ω terminator is OFF.

Table 2-3 Switch Functions

Switch	Function
1 to 5	Set the address for the speed dome
6, 7	Set the baudrate for the speed dome
8, 9	Set the protocol for the speed dome
10	Reserved

The DIP switch is designed according to binary system. When the switch is ON, it stands for the number 1. When the switch is OFF, it stands for the number 0.

Example:

The switches from No. 1 to 5 are used to set the speed dome address. No. 1 is the lowest digit and No. 5 is the highest. Turning on all these 5 switches stands for the binary number 11111. Converting the 11111 to a decimal number is 31. So the speed dome address will be 31.

◆ Address List

For convenient settings, refer to the following list to set the address for the speed domes.

Table 2-4 Dome Address

Switch Dome Address	1	2	3	4	5
0	OFF	OFF	OFF	OFF	OFF
1	ON	OFF	OFF	OFF	OFF
2	OFF	ON	OFF	OFF	OFF
3	ON	ON	OFF	OFF	OFF
4	OFF	OFF	ON	OFF	OFF
5	ON	OFF	ON	OFF	OFF
6	OFF	ON	ON	OFF	OFF
7	ON	ON	ON	OFF	OFF
8	OFF	OFF	OFF	ON	OFF
9	ON	OFF	OFF	ON	OFF
10	OFF	ON	OFF	ON	OFF
11	ON	ON	OFF	ON	OFF
12	OFF	OFF	ON	ON	OFF
13	ON	OFF	ON	ON	OFF
14	OFF	ON	ON	ON	OFF
15	ON	ON	ON	ON	OFF
16	OFF	OFF	OFF	OFF	ON
17	ON	OFF	OFF	OFF	ON
18	OFF	ON	OFF	OFF	ON
19	ON	ON	OFF	OFF	ON
20	OFF	OFF	ON	OFF	ON
21	ON	OFF	ON	OFF	ON
22	OFF	ON	ON	OFF	ON
23	ON	ON	ON	OFF	ON
24	OFF	OFF	OFF	ON	ON
25	ON	OFF	OFF	ON	ON
26	OFF	ON	OFF	ON	ON
27	ON	ON	OFF	ON	ON
28	OFF	OFF	ON	ON	ON
29	ON	OFF	ON	ON	ON
30	OFF	ON	ON	ON	ON
31	ON	ON	ON	ON	ON

◆ Baudrate List

For convenient settings, refer to the following list to set the baudrate for the speed dome. The baudrate will be set as 2400bps by default if it is out of this range.

Table 2-5 Baudrate

Switch \ Baudrate	6	7
2400	OFF	OFF
4800	ON	OFF
9600	OFF	ON
19200	ON	ON

◆ Protocol List

For convenient settings, refer to the following list to set the protocol for the speed dome.

Table 2-6 Protocol

Protocol	8	9
Self-adaptive	OFF	OFF
Pelco_D	OFF	ON
Pelco_P	ON	OFF
AD Manchester	ON	ON



The speed dome is self-adaptive to private protocol when the No.8 and 9 switches are both OFF.

2.2.3 7-inch IR Speed Dome Settings

Two DIP switches SW1 and SW2 are for setting the speed dome address, baudrate, protocol, etc., with value ON=1 and OFF=0. The switch label is on the back of the SWITCH cover as shown in Figure 2-9.

Each number of the switch represents a DIP value, ranging from 1 to 8 for the lowest to highest.

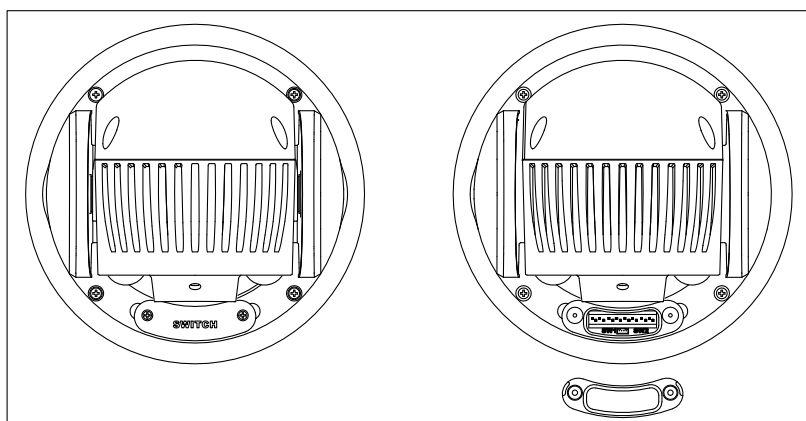

Figure 2-9 Label of DIP Switch for 7-inch IR Speed Dome



Figure 2-10 Enlarged View of DIP Switch



The default dome address is 0; the default baudrate is 2400; and the default value of the 120Ω terminator is OFF.

◆ Address Settings

The SW1 switch is used for setting the address of speed dome. You can refer to Table 2-7 for details of setting the speed dome address to a specific number.

Table 2-7 Set the Dome Address

Dome Address	1	2	3	4	5	6	7	8
0	OFF	OFF	OFF	OFF	OFF	OFF	OFF	OFF
1	ON	OFF	OFF	OFF	OFF	OFF	OFF	OFF
2	OFF	ON	OFF	OFF	OFF	OFF	OFF	OFF
3	ON	ON	OFF	OFF	OFF	OFF	OFF	OFF
...
255	ON	ON	ON	ON	ON	ON	ON	ON

◆ Baudrate Settings

The No. 1, 2 and 3 of SW2 switch are for setting the baudrate of the speed dome, standing for 2400bps, 4800bps and 9600bps respectively. The baudrate will be set as 2400bps by default if it is out of this range. Refer to the following table:

Table 2-8 Set the Baudrate of the Dome

DIP Switch SW2-Baudrate Settings			
Baudrate	1	2	3
2400	ON	OFF	OFF
4800	OFF	ON	OFF
9600	ON	ON	OFF
19200	OFF	OFF	ON

◆ Protocol Settings

The speed dome is self-adaptive to PELCO-D, PELCO-P and private protocol which cannot set by the DIP switches.

◆ Communication Mode Settings

The No. 7 of SW2 switch is for setting the RS485 communication mode of the dome to simplex or half-duplex.

Table 2-9 Set Communication Mode of the Dome

DIP Switch SW2-Simplex/Half-duplex Settings	
Description	7
Simplex	OFF
Half-duplex	ON

◆ Terminal Resistor Settings

The No. 8 of SW2 switch is used for turning on/off the 120Ω terminal resistor.

Table 2-10 Set Terminal Resistor

Switch No.	8
Description	
Turn on the resistor	OFF
Turn off the resistor	ON



The o-ring in the groove of the switch cover is for waterproof.

2.2.4 Mini Speed Dome Settings

● DIP Switch Location of Mini IR Speed Dome

Steps:

1. Remove the switch cover as shown in Figure 2-11(left).
2. Set the address and baudrate with DIP switch.
3. Install the switch cover back to the speed dome.

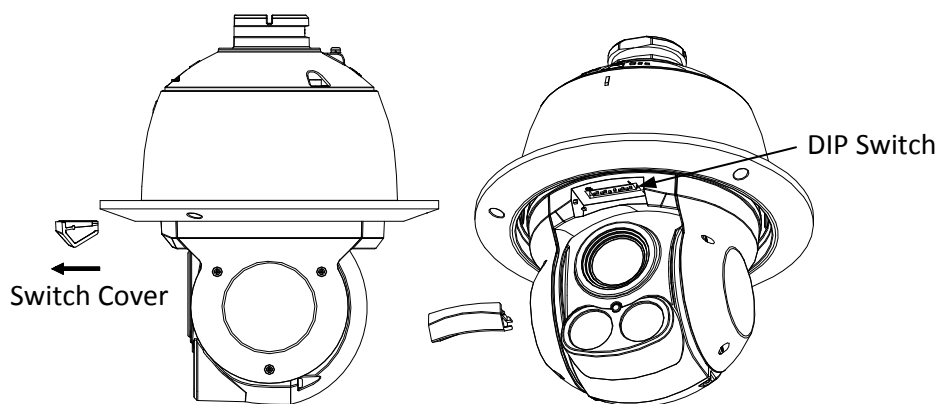

Figure 2-11 DIP Switch of Mini IR Speed Dome

● DIP Switch Location of Mini Analog Speed Dome

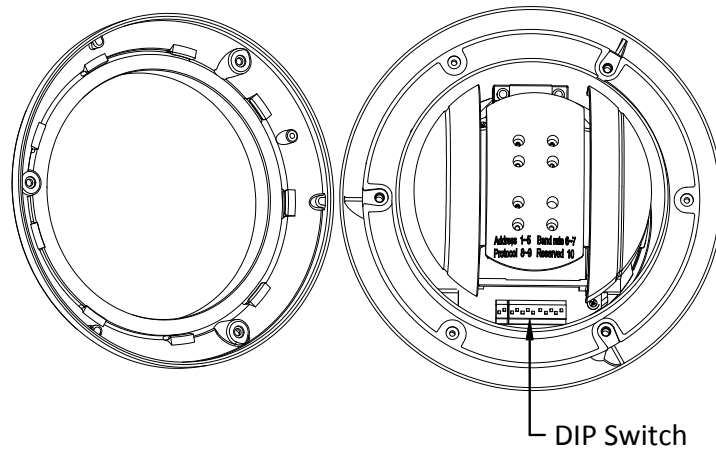

Figure 2-12 DIP Switch of Mini Analog Speed Dome

● Setting DIP Switch

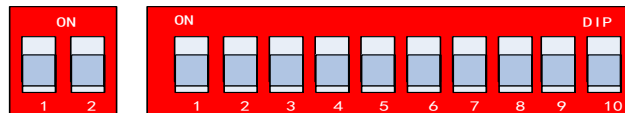

Figure 2-13 Enlarged View of DIP Switch



- For some certain models, the two individual DIP switches at the left side of the Figure 2-8 are supported for turning on/off the terminator; while other models are not supported.
- The default dome address is 0; the default baudrate is 2400; and the default value of the 120Ω terminator is OFF.

Table 2-11 Switch Functions

Switch No.	Function
1 to 5	Set the address for the speed dome
6, 7	Set the baudrate for the speed dome
8, 9	Set the protocol for the speed dome
10	Reserved

The DIP switch is designed according to binary system. When the switch is ON, it stands for the number 1. When the switch is OFF, it stands for the number 0.

Example:

The switches from No. 1 to 5 are used to set the speed dome address. No. 1 is the lowest digit and No. 5 is the highest. Turning on all these 5 switches stands for the binary number 11111. Converting the 11111 to a decimal number is 31. So the speed dome address will be 31.

◆ Address List

For convenient settings, refer to the following list to set the address for the speed domes.

Table 2-12 Dome Address

Switch No. Dome Address	1	2	3	4	5
0	OFF	OFF	OFF	OFF	OFF
1	ON	OFF	OFF	OFF	OFF
2	OFF	ON	OFF	OFF	OFF
3	ON	ON	OFF	OFF	OFF
...
31	ON	ON	ON	ON	ON

◆ Baudrate List

For convenient settings, refer to the following list to set the baudrate for the speed dome. The baudrate will be set as 2400bps by default if it is out of this range.

Table 2-13 Baudrate

Switch No. Baudrate	6	7
2400	OFF	OFF
4800	ON	OFF
9600	OFF	ON
19200	ON	ON

◆ Protocol List

For convenient settings, refer to the following list to set the protocol for the speed dome.

Table 2-14 Protocol

Switch No. Protocol	8	9
Self-adaptive	OFF	OFF
Pelco_P	ON	OFF



The speed dome is self-adaptive to private protocol when the No.8 and 9 switches are both OFF.

2.3 Wiring and Installation

There are several ways to install the speed dome. The wall mounting is taken as an example below.

2.3.1 Wiring

The survey of the actual installation environment and planning the wiring is highly recommended before the accurate deployment of the wire is implemented in order to provide a safe and steady

power supply and a reasonable wiring route.

- Get familiar with the installation environment before deploying the wire, including the wiring distance, surrounding, and electromagnetic interference and so on.
- Please choose the cable with nominal voltage higher than the actual voltage, to ensure a normal running in case of unsteady voltage.
- To protect the power cable and the signal transmitting cable from human tampering, you should pay attention to the protection and reinforcement of the cables.
- When deploying the wire, please do not tighten the wire or make the wire loose.

The wiring of the speed dome should be performed by professionals.

2.3.2 Installing the Bracket

Before you start:

Wall mounting is applicable to the indoor/outdoor solid wall construction. The followings are the mandatory precondition for wall mounting:

- The wall must be thick enough to install the expansion screws.
- Please make sure that the wall is strong enough to withstand more than 8 times the weight of the dome and the bracket.

Steps:

1. Check whether the type of the bracket and the number of accessories are right, as shown in the figure below.

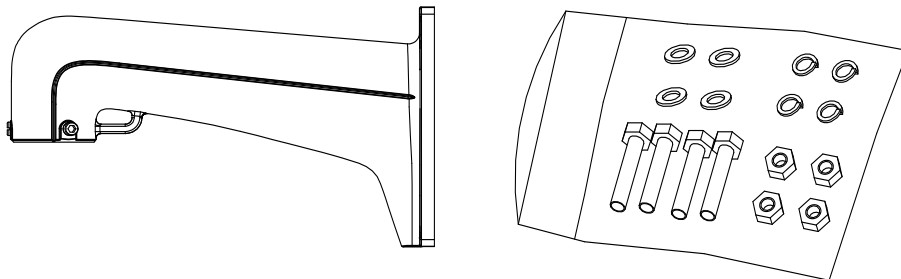

Figure 2-14 Wall Mounting Bracket, Nuts and Flat Washers

2. Drill 4 screw holes in the wall according to the holes of the bracket, and then insert M8 expansion screws (not supplied) into the mounting holes.

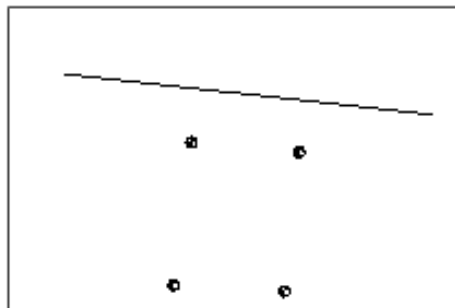

Figure 2-15 Drill Mounting Holes

3. Attach the bracket to the wall by aligning the 4 screw holes of the bracket with expansion screws on the wall.
4. Secure the bracket with 4 hex nuts and washers.

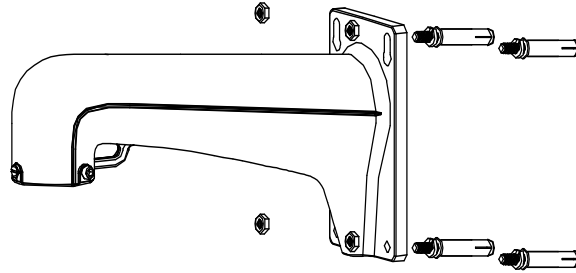

Figure 2-16 Secure the Bracket

5. Install the speed dome to the bracket. Please refer to *Section 2.3.4 Installing the Speed Dome* for installation details.



Follow the same instructions described above for the short-arm wall mounting. For outdoor applications, please adopt the water-proof measures. The short-arm wall bracket is not recommended for outdoor applications.

2.3.3 Setting the DIP Switch

Set the DIP Set the address and baudrate for the analog speed dome. The default value of DIP switch is shown below:

- ◆ **Address: 0**
- ◆ **Baudrate:2400**
- ◆ **Terminal Resistor: OFF**

Please refer to the *Section 2.2 DIP Switch Settings* for DIP switch settings.

2.3.4 Installing the Speed Dome



The sketched of installing the speed dome are for reference only.

Steps:

1. Hang the safety rope to the speed dome and then hook to the bracket as shown in Figure 2-17.

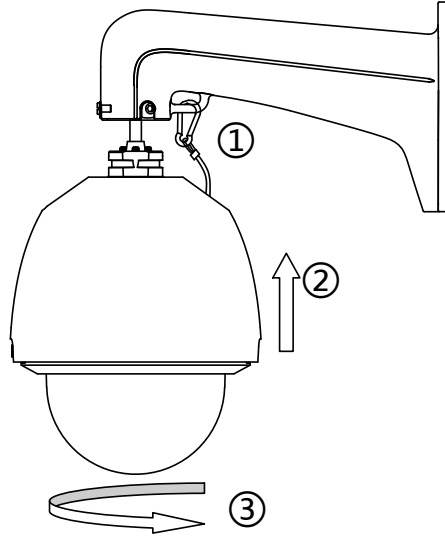

Figure 2-17 Mount the Dome

2. Route the cables of the speed dome through the bracket.
3. Connect the corresponding video/power/RS-485 cables.
4. Install the speed dome to the bracket, and secure the speed dome by rotating the speed dome clockwise.
5. Fasten the two lock screws with the Allen wrench.

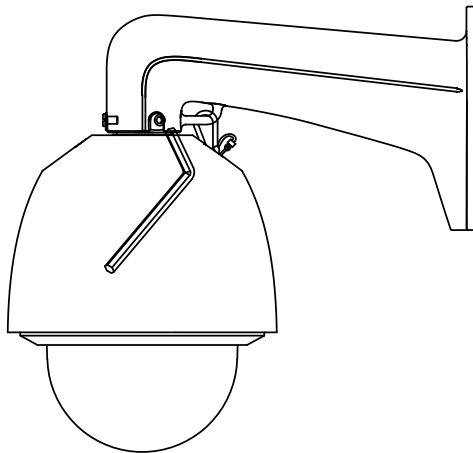

Figure 2-18 Tighten the Lock Screws

Chapter 3 In-door Mounting Applications

Before you start:

- For cement wall, you need to use the expansion screw to fix the bracket. The mounting hole of the expansion pipe on the wall should align with the mounting hole on the bracket.
- For wooden wall, you can just use the self-tapping screw to fix the bracket.

3.1 5-inch Speed Dome In-ceiling Mounting Applications

Before you start:

The in-ceiling mounting is applicable to the indoor ceiling construction. The followings are the mandatory precondition for mounting:

- The height of the space above the ceiling must be more than 250mm.
- The thickness of the ceiling must ranges from 5 to 40mm.
- The ceiling must be strong enough to withstand more than 4 times the weight of the dome and its accessories.

Steps

1. Rotate the lower dome counterclockwise to separate it from the back box as shown in Figure 3-1.
2. Remove the protective lens cover, foam and sticker from the dome drive.
3. Set the address and baudrate for the analog speed dome. Please refer to the *Section 2.2.1 5-inch Speed Dome Settings* for DIP switch settings.
4. Attach lower dome to the back box, and rotate clockwise to secure it.

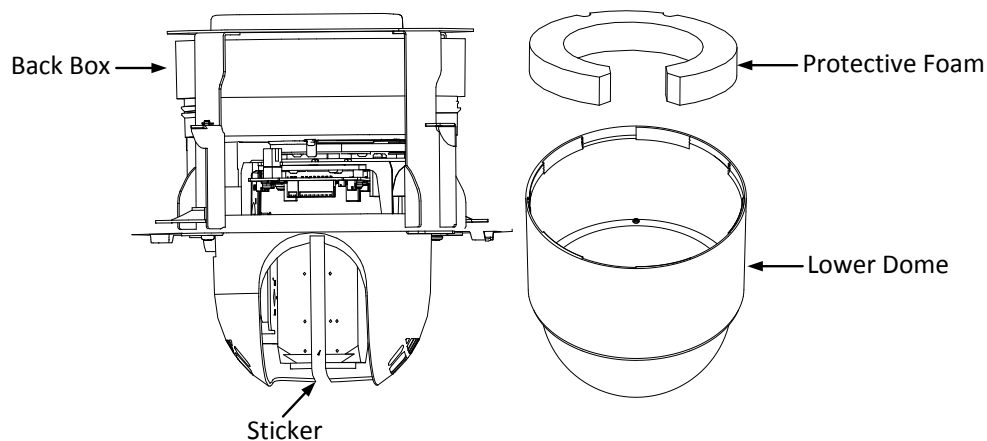

Figure 3-1 Remove the Protective Accessory

5. Drill a hole on the ceiling according to the drill template (supplied).



±2mm of the diameter of the circle is tolerable.

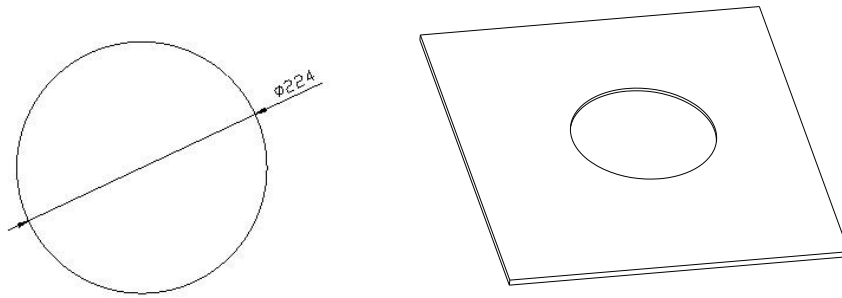

Figure 3-2 Draw and Cut Hole on the Ceiling

6. Connect the cables.

Make sure the video cable and control wire have been connected to the corresponding interfaces. Connect the power cable and the red LED indicator turns on when the power is on.



Please turn the power off after checking the speed dome.

7. Install the speed dome.

- (1) Loosen the two lock screws on both sides of the back box and make the locks in internal position, as shown in the following figure:

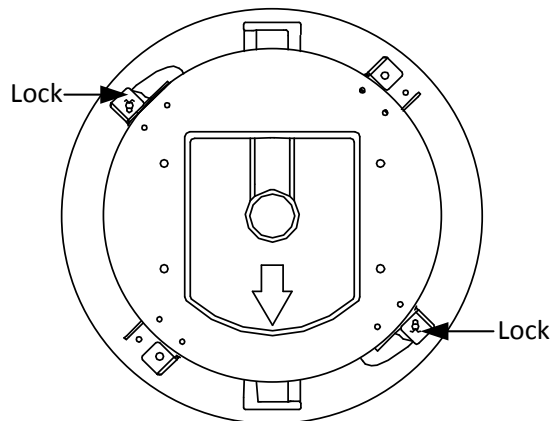

Figure 3-3 Locks and Lock Screws

- (2) Push the back box into the mounting hole in the ceiling
- (3) Tighten the lock screws with the screwdriver and the locks will automatically rotate outwards to secure the in-ceiling mounting bracket to the ceiling.

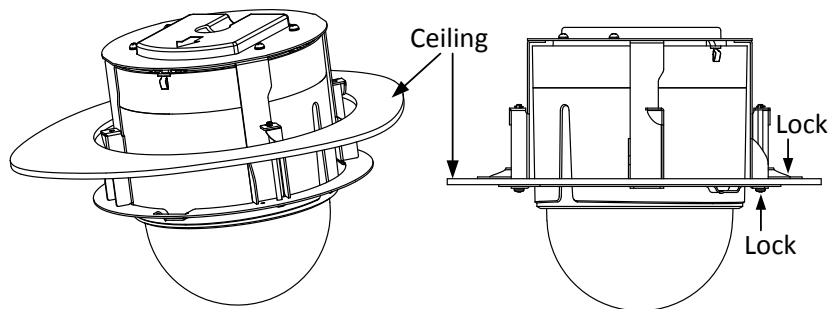

Figure 3-4 Install the back box

8. Install the trim ring.

- (1) Attach the trim ring to the lower dome and align the triangular notch of the trim ring with the arrow label on the in-ceiling mounting bracket.
- (2) After having firmly placed the trim ring to the ceiling, rotate the trim ring in the direction of arrow to secure the trim ring in place.



- Please remove the protective film on the lower dome after the installation is finished.
- In order to obtain clear video images, please wear the anti-static gloves when you install the speed dome.

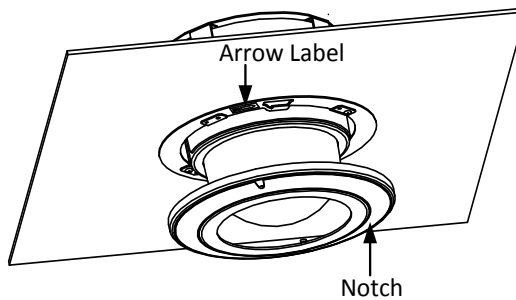

Figure 3-5 Install the Trim Ring

3.2 5-inch Speed Dome Ceiling Mounting Applications

Before you start:

The ceiling mounting is applicable to the indoor/outdoor solid ceiling construction. The followings are the mandatory precondition for ceiling mounting:

- The thickness of the ceiling must ranges from 5 to 40mm.
- The ceiling must be strong enough to withstand more than 4 times the weight of the dome and its accessories.

3.2.1 Removing the Mounting Bracket

It is required to modify the external structure of the in-ceiling mounting speed dome before the operation of ceiling mounting.

Steps:

1. Remove the 4 screws on the back box by a Phillips screwdriver.

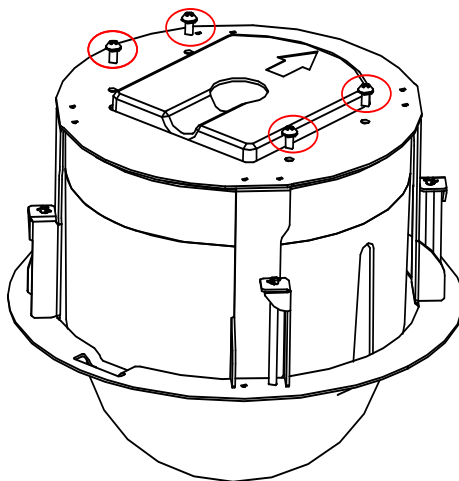

Figure 3-6 Remove 4 screws

2. Remove the in-ceiling mounting bracket.

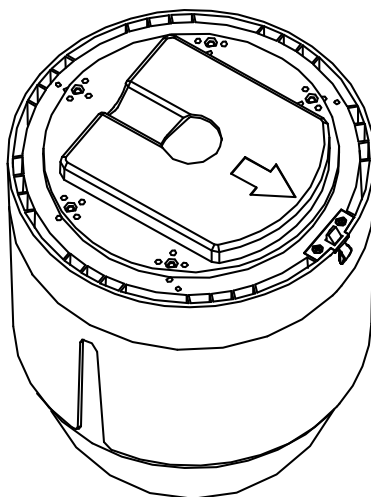

Figure 3-7 Remove the in-ceiling mounting bracket

3. Screw 4 bolts onto the back box by a Phillips screwdriver.

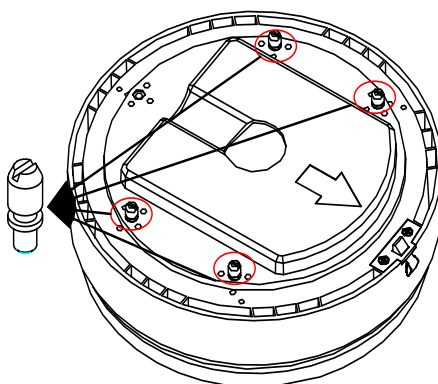

Figure 3-8 Install the bolts

3.2.2 Wiring

The cables of dome can be routed either from the top or the side of the back box. For the cables routed from the top of the back box, it is required to drill a cable hole in the ceiling.

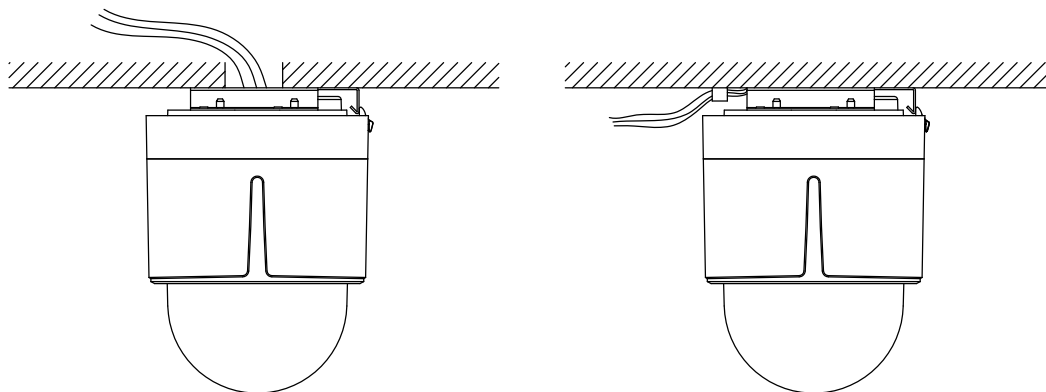

Figure 3-9 Cabling for Ceiling Mounting

3.2.3 Ceiling Mounting

Steps:

1. Rotate the lower dome counterclockwise to separate it from the back box. Refer to the Figure 3-1.
2. Remove the protective lens cover, foam and sticker from the dome drive.
3. Set the address and baudrate for the analog speed dome. Please refer to the *Section 2.2.1 5-inch Speed Dome Settings* for DIP switch settings.
4. Attach lower dome to the back box, and rotate clockwise to secure it.
5. Use the mounting base as a template to mark four screw holes onto the ceiling.
6. If you route cables from the top of the back box, mark the cable hole on the ceiling and drill a hole.

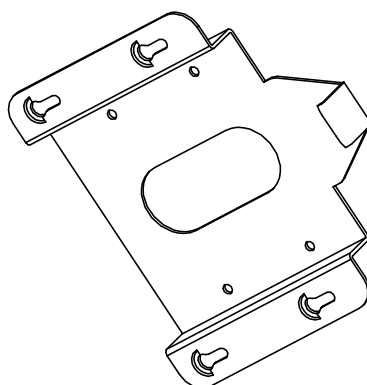

Figure 3-10 Mark the Screw Positions

7. Secure the mounting base to the ceiling with set screws.
 - If the speed dome is installed to the wooden wall, use the self-tapping screws to secure the mounting base.

- If the dome is installed to the cement wall, drill three $\Phi 5$ mounting holes onto the wall according to the hole locations, and then insert the cement screws into the holes and finally use self-tapping screws to secure the mounting base to the wall.

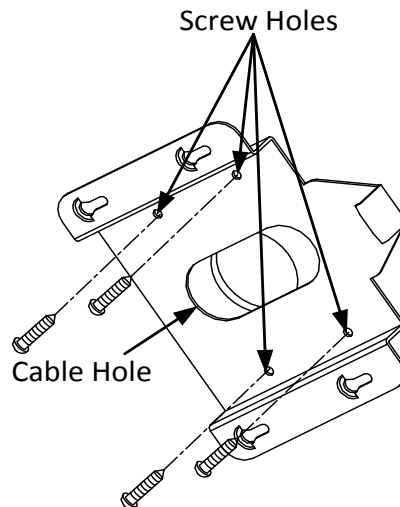

Figure 3-11 Secure the Mounting Base

8. Install the speed dome to the mounting base.
 - (1) Route the cables for the speed dome. Align the bottom of the speed dome with the mounting base.
 - (2) Line up the direction of arrow with the spring end of the mounting base.
 - (3) Push the speed dome upwards and then forwards in the direction of arrow. When the speed dome is placed in position, the spring will automatically snap into the lock clip firmly. Refer to the following figure.

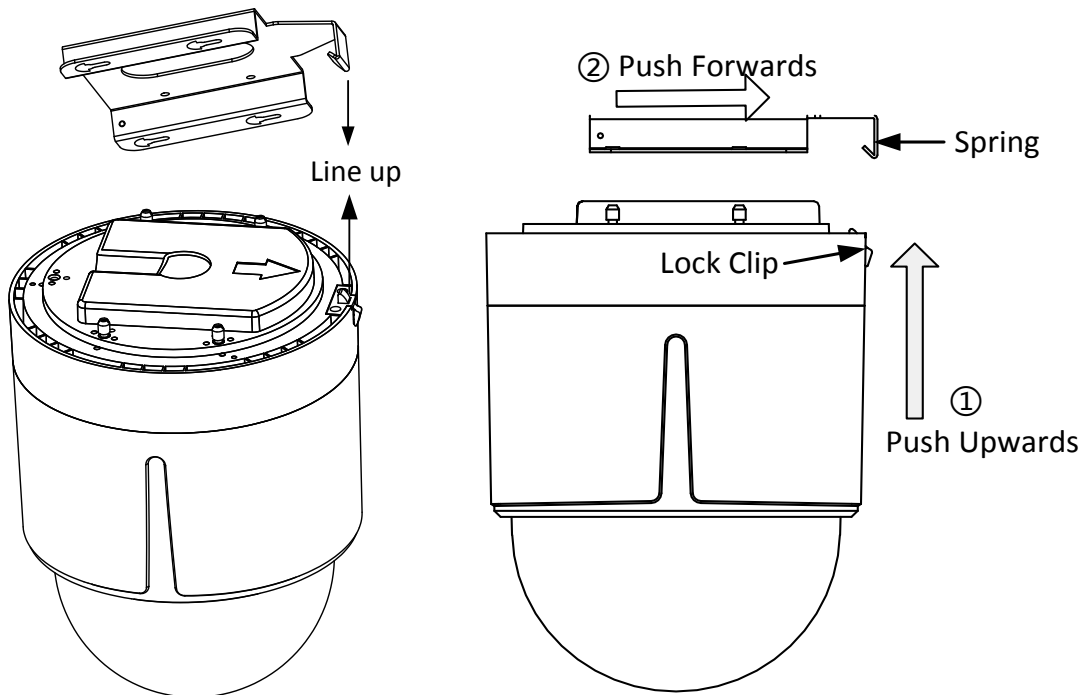

Figure 3-12 Attach the Back Box to the Mounting Base



- Please remove the protective film on the lower dome after the installation is finished.
- Do not touch the bubble of the lower dome directly by hand. The image blurs otherwise.

3.3 Mini Speed Dome In-ceiling Mounting Applications

3.3.1 Mini Analog Speed Dome In-ceiling Mounting

Before you start:

The in-ceiling mounting is applicable to the indoor ceiling construction. The followings are the mandatory precondition for mounting:

- The height of the space above the ceiling must be more than 250mm.
- The ceiling must be with the thickness between 5 and 40mm.
- The ceiling must be strong enough to withstand more than 4 times the weight of the dome and its accessories.

Steps:

1. Drill holes in the ceiling.
 - 1) Attach the drill template to the ceiling where you need to install the speed dome.
 - 2) Cut a hole and drill screw holes according to the drill template.



±2mm of the diameter of the circle is tolerable.

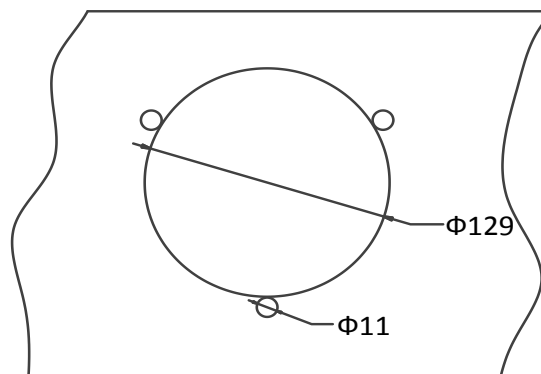

Figure 3-13 Drill Holes

2. Disassemble the speed dome.
 - 1) Loosen three screws as shown in the following figure.
 - 2) Remove the lower dome.
 - 3) Loosen three screws and remove the back box.
 - 4) Remove the protective lens cover, foam and sticker from the dome drive.

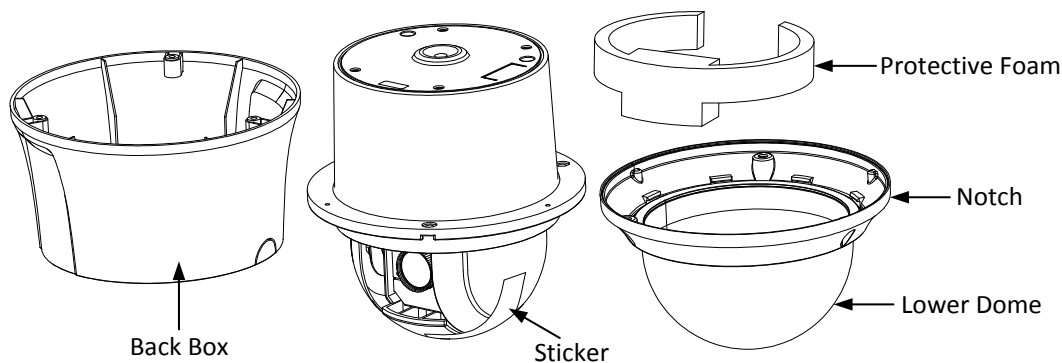

Figure 3-14 Disassemble the Speed Dome

3. Install the toggle bolts.
 - 1) Remove the toggle from the toggle bolt.
 - 2) Insert the bolts into the screw holes on the dome.
 - 3) Rotate the bolts through the screw holes.
 - 4) Reinstall the toggles as shown in Figure 3-15.

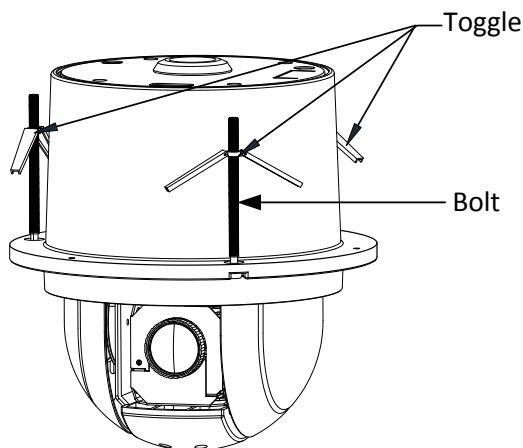

Figure 3-15 Install the Toggle Bolts

4. Align the toggle bolts with the screw holes on the ceiling.
5. Push the dome to the mounting hole on the ceiling.
6. Rotate the bolts again. The toggle will automatically rotate down to secure the dome to the ceiling.

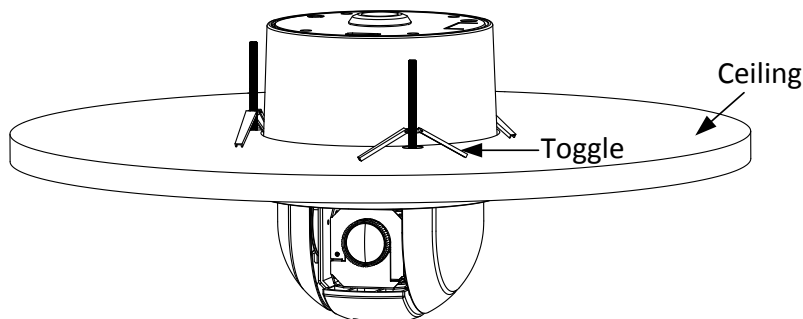

Figure 3-16 Install the Dome to the Ceiling

7. Secure the lower dome to the back box with three screws as shown in Figure 3-17.

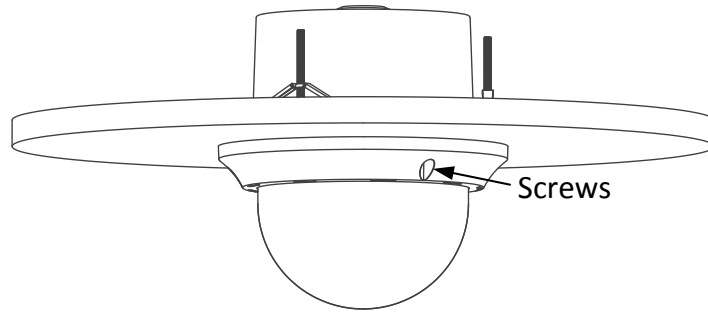

Figure 3-17 Install the Lower Dome

8. Route the cables through the ceiling for the speed dome. Please refer to the *section 2.1 Cable Descriptions* for connecting the cables.

3.3.2 Mini IR Speed Dome In-ceiling Mounting

Before you start:

The in-ceiling mounting is applicable to the indoor ceiling construction. The followings are the mandatory precondition for mounting:

- The height of the space above the ceiling must be more than 250mm.
- The ceiling must be with the thickness between 5 and 40mm.
- The ceiling must be strong enough to withstand more than 4 times the weight of the dome and its accessories.

Steps:

1. Set the address, baudrate and protocol. For the detailed DIP switch settings, please refer to *Section 2.2.4 Mini Speed Dome Settings*.
2. Drill holes in the ceiling.
 - 1) Attach the drill template to the ceiling where you need to install the speed dome.
 - 2) Cut a hole and drill screw holes according to the drill template.



±2mm of the diameter of the circle is tolerable.

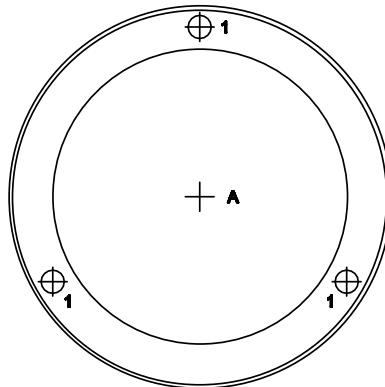

Figure 3-18 Drill Template

3. Route the cables through the ceiling for the speed dome. Please refer to the section *1.1*

Connecting the Cables for connecting the cables.

4. Install the toggle bolts.
 - 1) Remove the toggle from the toggle bolt.
 - 2) Insert the bolts into the 3 screw holes on the dome.
 - 3) Rotate the bolts through the 3 screw holes.
 - 4) Reinstall the toggles as shown in Figure 3-19.

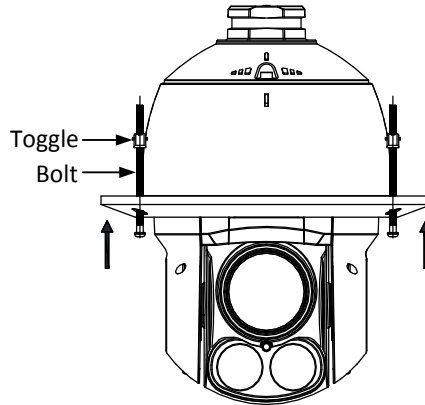

Figure 3-19 Install Toggle Bolts

5. Align the toggle bolts with the screw holes on the ceiling.
6. Push the dome to the mounting hole on the ceiling.

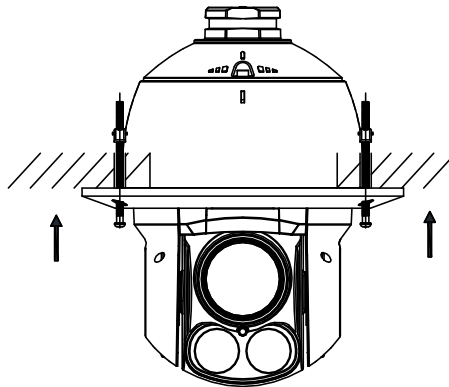

Figure 3-20 Push to the Mounting Hole

7. Rotate the bolts again. The toggle will automatically rotate down to secure the dome to the ceiling.

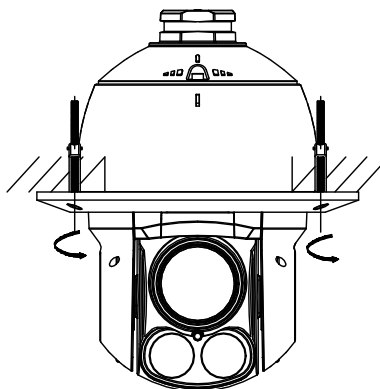

Figure 3-21 Install the Dome to the Ceiling

3.4 Mini Speed Dome Ceiling Mounting Applications

Before you start:

The ceiling mounting is applicable to the indoor/outdoor solid ceiling construction. The followings are the mandatory precondition for ceiling mounting:

- The ceiling must be with the thickness between 5 and 40mm.
- The ceiling must be strong enough to withstand more than 4 times the weight of the dome and its accessories.

3.4.1 Wiring

The cables of dome can be routed either from the top or the side of the back box, as shown in Figure 3-22. For the cables routed from the top of the back box, it is required to drill a cable hole in the ceiling.

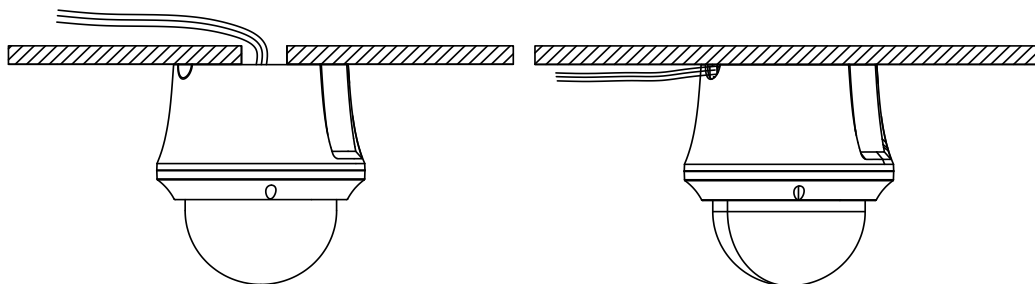

Figure 3-22 Cabling for Ceiling Mounting

3.4.2 Ceiling Mounting

Steps:

1. Drill Screw holes in the ceiling.
 - 1) Attach the drill template to the ceiling where you need to install the speed dome.
 - 2) Drill screw holes and a cable hole (optional) according to the drill template.

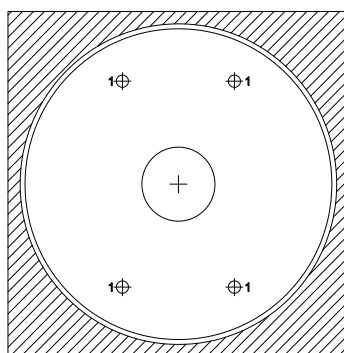

Figure 3-23 Drill Template

2. Disassemble the speed dome.

- 1) Loosen three screws on the notch.
- 2) Remove the lower dome.
- 3) Remove the protective lens cover, foam and sticker from the dome drive as shown in Figure 3-24.

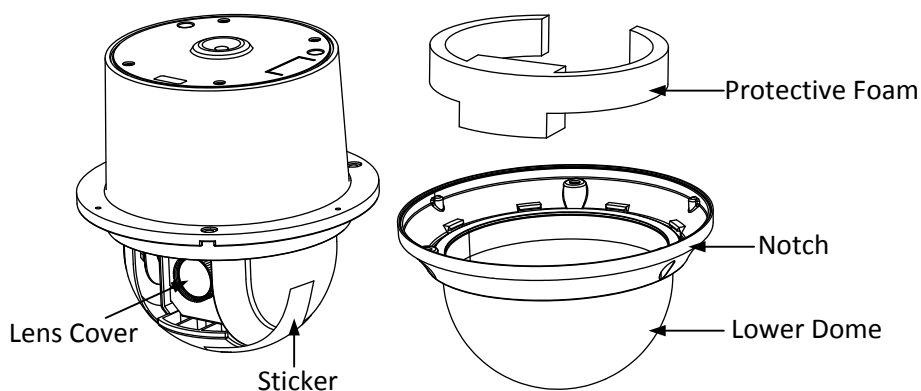

Figure 3-24 Disassemble the Speed Dome

3. Attach lower dome to the back box, and secure it with screws.
4. Align the ceiling mounting bracket with the screw holes on the drill template. Secure the ceiling mounting bracket to the ceiling with screws (supplied).

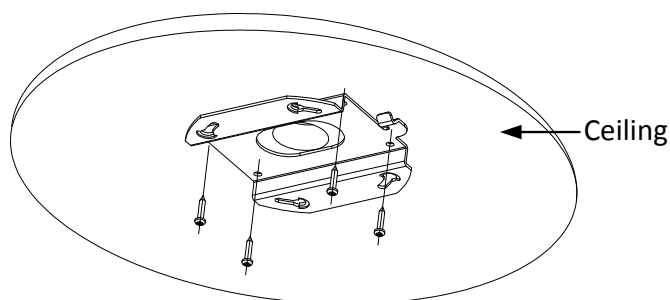

Figure 3-25 Install Ceiling Mounting Bracket

5. Align the hook of the ceiling with unlock label on the speed dome.
6. Push the speed dome to the ceiling mounting bracket and rotate clockwise to secure it.

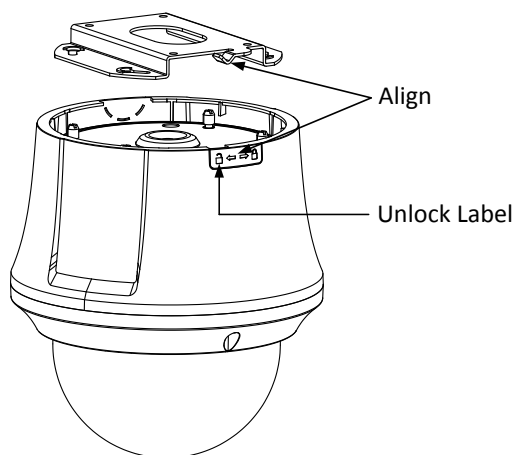

Figure 3-26 Install Speed Dome



- For cement ceiling mounting, you need to use the expansion screw to fix the bracket. The mounting hole of the expansion pipe on the wall should align with the mounting hole on the bracket.
- For wooden ceiling mounting, you can just use the self-tapping screw to fix the bracket.

Appendix

Appendix 1 Lightning & Surge Protection

This product adopts TVS plate lightning protection technology to avoid damage caused by pulse signal that is below 3000W, like instantaneous lighting stroke, surging, etc. According to the actual outdoor situation, necessary protection measures must be taken, besides ensuring the electrical safety.

- The distance between signal transmission wires and High-voltage equipment or high-voltage cable is at least 50m.
- Outdoor wiring should better be routed under eaves as much as possible.
- In the open field, wiring should be buried underground in sealed steel pipe, and the steel-pipe should be one-point grounding. Overhead routing method is forbidden.
- In strong thunderstorm area or high induction voltage areas (such as high-voltage transformer substation), high power lightning protection apparatus and lightning conductor are necessary to be added.
- The design of lightning protection and grounding of the outdoor devices and cables should be considered together with the lightning protection demand of buildings. It also must conform to the related national standards and industrial standards.
- The system should be equipotential grounded. The grounding equipment must conform to the demands of system anti-jamming and electrical safety both and it must not appear short circuit or mixed circuit with the zero conductor of strong grid. When the system is grounded alone, the resistance should be no more than 4Ω . The sectional area of the grounding cable should be no less than 25mm^2 . For grounding instructions, please refer to the Installation Manual of Speed Dome.

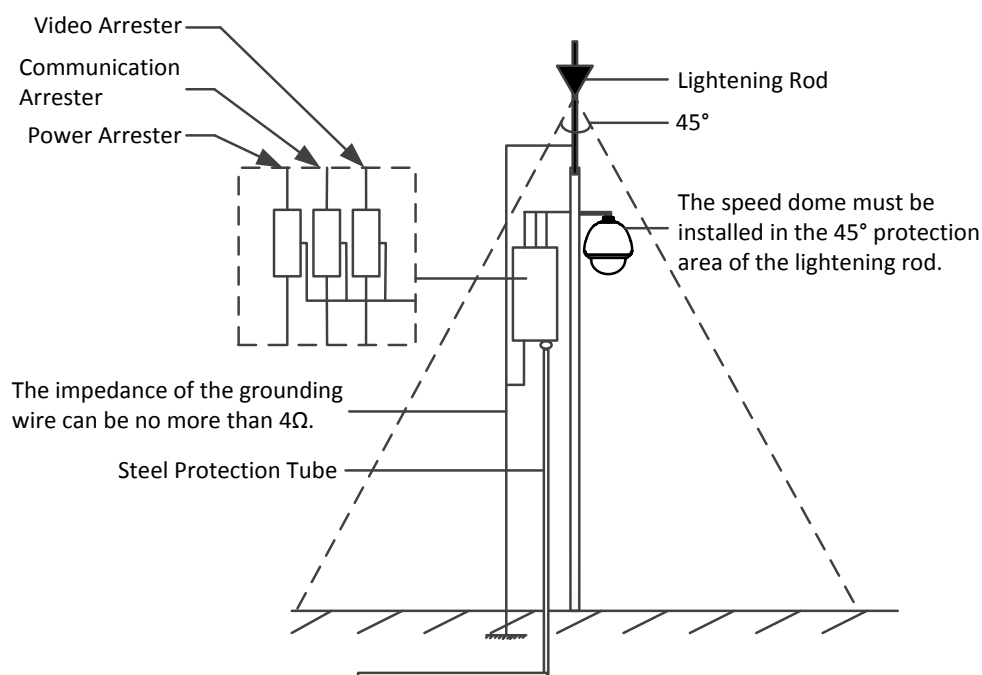

Figure A-1 Lightning & Surge Protection

Appendix 2 RS485 Bus Connection

● General Property of RS485 Bus

According to RS485 industry bus standard, RS485 is a half-duplex communication bus which has 120Ω characteristic impedance, the maximum load ability is 32 payloads (including controller device and controlled device).

● RS485 Bus Transmission Distance

When using 0.56mm (24AWG) twisted-pair line, according to different baudrate, the maximum transmission distance theory table is shown as below:

Table A-1 Max. Distance of RS485 Transmission

Baudrate	Max Distance
2400BPS	1800m
4800BPS	1200m
9600BPS	800m

The transmission distance will be decreased if we use the thinner cable, or use this product under the strong electromagnetic interference situation, or there are lots of devices are added to the bus; on the contrary, the transmission distance will be increased.

● Connection Methods

RS485 industry bus standard require daisy-chain connection method between any devices, both sides have to connect a 120Ω terminal resistance (show as Diagram 1), the simplified connection method is shown as diagram 2, but the distance of "D" should not be too long.

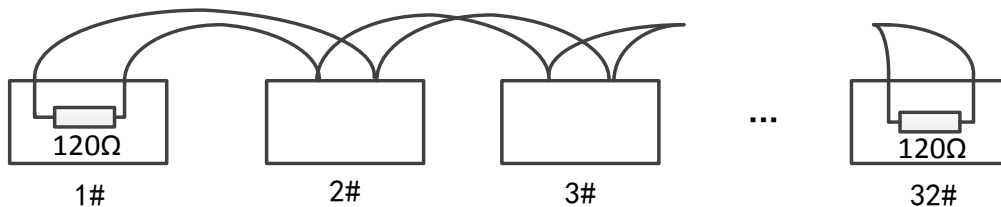

Figure A-2 RS485 Connection 1

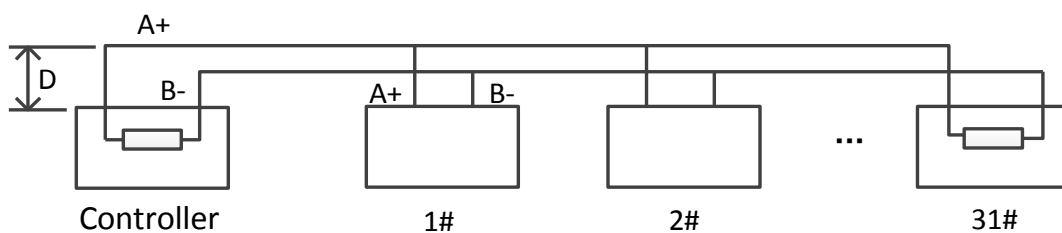

Figure A-3 RS485 Connection 2

● Problems in the Practical Application

Normally, users adopt star-shape connection method in construction, under this situation, the terminal resistors must be connected between two farthest devices (as Figure 4, 1# and 15#), but this connection method is not satisfy the requirement of the RS485 industry standard so that it will lead to some problems such as signal reflection, anti-jamming ability decline when the devices are

faraway. At this time, the dome will be uncontrollable, or self-running, etc.

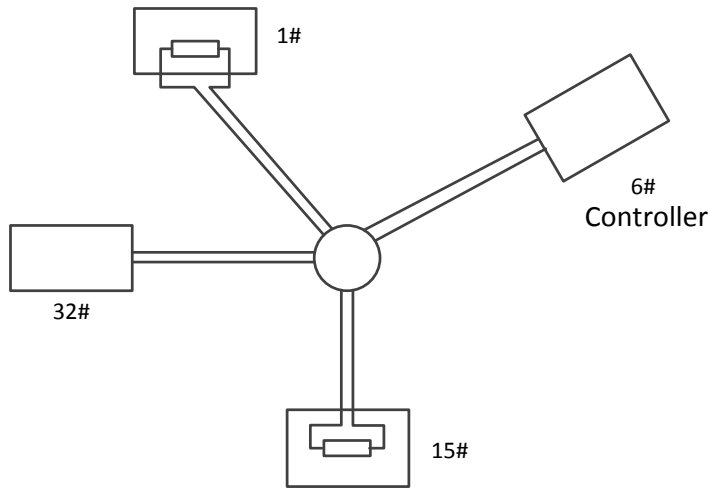

Figure A-4 Star Shape Connection

For such case, the best way is adding a RS485 distributor. This product can effectively change the star-shape connection to which satisfies the requirement of RS485 industry standard, in order to avoid those problems and improve the communication reliability. Show as figure 5.

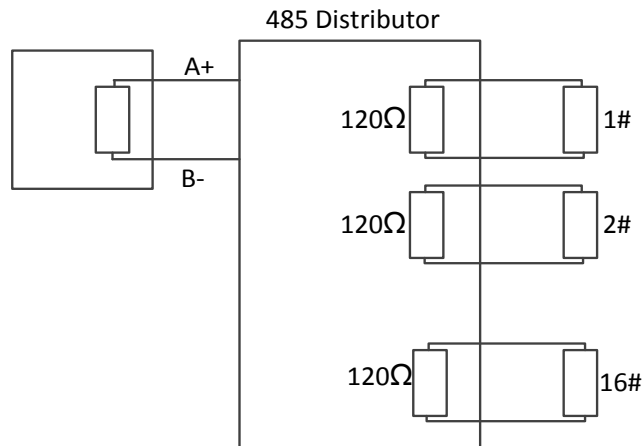

Figure A-5 RS485 Distributor

● Troubleshooting of RS485 communication

Problem	Possible Reasons	To Solve the Problem
The speed dome does the self-test action but cannot be controlled remotely.	1. The address or baudrate of the speed dome does not match with those of remote control device.	1. Adjust the address and baudrate of the remote control device to match with those of the speed dome.
	2. The wire RS485+ connects to the interface RS485- and wire RS485- connects to the interface RS485+.	2. Connect the wire RS485+ to the interface RS485+ and wire RS485- to the interface RS485-.
	3. The RS485 wire is disconnected.	3. Reconnect the RS485 wire tightly.
	4. RS485 wire is broken.	4. Change a RS485 wire.
The speed	1. The connection is loose.	1. Reconnect the RS485 wire

Problem	Possible Reasons	To Solve the Problem
dome can be controlled but not smoothly.		tightly.
	2. RS485+ or RS485-wire is broken.	2. Change a RS485 wire.
	3. The speed dome is too far away from the remote control device.	3. Add a terminal resistor.
	4. Too many speed domes are connected.	4. Add a RS485 distributor.

Appendix 3 24VAC Wire Gauge & Transmission Distance

The following table describes the recommended Max. distance adopted for the certain wire gauge when the loss rate of 24VAC voltage is less than 10%. For the AC driven device, the maximum voltage loss rate is 10% allowable. For example, for a device with the rating power of 80VA which is installed at a distance of 35 feet (10m) away from the transformer, then 0.8000mm is required as the minimum wire gauge.

Distance (feet) \ Wire Gauge (mm) \ Power (va)	0.8000	1.000	1.250	2.000
10	283(86)	451(137)	716(218)	1811(551)
20	141(42)	225(68)	358(109)	905(275)
30	94(28)	150(45)	238(72)	603(183)
40	70(21)	112(34)	179(54)	452(137)
50	56(17)	90(27)	143(43)	362(110)
60	47(14)	75(22)	119(36)	301(91)
70	40(12)	64(19)	102(31)	258(78)
80	35(10)	56(17)	89(27)	226(68)
90	31(9)	50(15)	79(24)	201(61)
100	28(8)	45(13)	71(21)	181(55)
110	25(7)	41(12)	65(19)	164(49)
120	23(7)	37(11)	59(17)	150(45)
130	21(6)	34(10)	55(16)	139(42)
140	20(6)	32(9)	51(15)	129(39)
150	18(5)	30(9)	47(14)	120(36)
160	17(5)	28(8)	44(13)	113(34)
170	16(4)	26(7)	42(12)	106(32)
180	15(4)	25(7)	39(11)	100(30)
190	14(4)	23(7)	37(11)	95(28)
200	14(4)	22(6)	35(10)	90(27)

Appendix 4 Wire Gauge Standards

Bare Wire Gauge(mm)	American Wire Gauge AWG	British Wire Gauge SWG	Cross-sectional Area of Bare Wire(mm ²)
0.750	21		0.4417
0.800	20	21	0.5027
0.900	19	20	0.6362
1.000	18	19	0.7854
1.250	16	18	1.2266
1.500	15	17	1.7663
2.000	12	14	3.1420
2.500			4.9080
3.000			7.0683