



333 Bayview Avenue Amityville, New York 11701
 For Sales and Repairs, (800) 645-9445
 For Technical Service, (800) 645-9440 or visit us at
<http://tech.napcosecurity.com/>
 (Note: Technical Service is for security professionals only)
 Publicly traded on NASDAQ Symbol: NSSC
 © NAPCO 2017

PIR1710 PASSIVE INFRARED SENSOR INSTALLATION INSTRUCTIONS

WI2242LF 05/17

SPECIFICATIONS

Coverage (l x w): 70' x 60' (21.3m x 18.3m) at 20°C (68°F), typical.

Operating Temperature: -10' to + 50°C (14° to 122°F)

Mounting: Wall or corner, 12' (3.6m) max.

Output: Normally-Closed Form-A Relay

Relay Time: Approximately 3 seconds

Contact Ratings, Alarm Relay: 100mA, 24VDC with internal 10Ω current-limiting resistor

Power-Supply Requirements

Note: This unit is intended for operation from a power source that provides a 4 hour battery backup in the event of a power failure.

Filtered DC: 10.6 to 16VDC nominal with battery backup from control panel.

Current Drain: 28mA (idle or alarm) at 12VDC (nominal)
 33mA (idle or alarm) at 16VDC (nominal)

Physical Dimensions: 3.3" x 2.5" x 1.9" (8.4cm x 6.4cm x 4.8cm) (H x W x D)

Shipping Weight: 5oz (142gm)

FEATURES

- Advanced Microprocessor-based circuitry
- Utilizes Analog to Digital Signal Conversion
- Vertical and horizontal aiming capabilities
- Dual-element sensor
- Large lens area assures high sensitivity
- Small size with ample wiring space
- Power filtering provides protection against transients
- Corner mountable
- Look Down Zone

STANDARD LENS

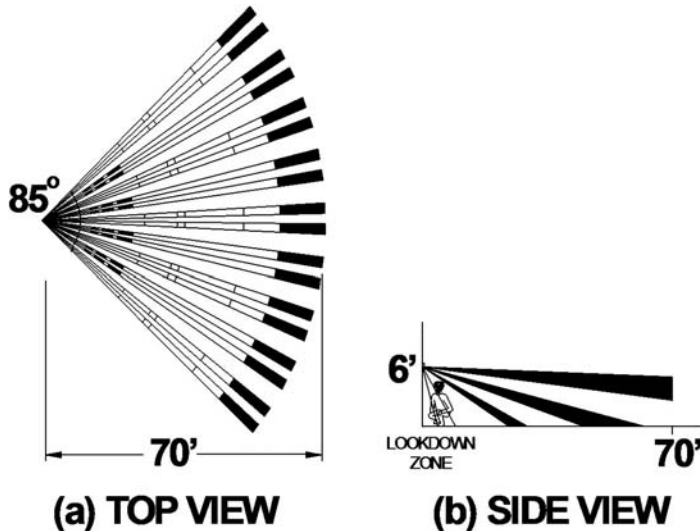

Standard Lens Coverage Pattern

MOUNTING & WIRING

Allow at least three minutes for the unit to settle. The LED will not function until the unit is ready. Do not point the unit at sources of heat, such as radiators, space heaters, etc. Adjust beams laterally by sliding the Lens Support horizontally within its retainers. Loosen the Height Lock Screw and set the board's height scale to the mounted height of the unit. Retighten the screw. To extinguish the LED after walk-testing, cut the jumper (see "Circuit Board Detail", below).

Sensitivity Setting (SEN Jumper)

The unit is shipped with no jumper in this position. This is the normal sensitivity mode and is recommended for most installations. To have faster catch performance or for a range greater than 50 feet, install the supplied jumper on the **SEN** header.

Vertical Aiming (refer to lens coverage pattern)

The height scale that is on the board is intended to make vertical aiming quick and easy. If the board is set to the same number as the height the unit is mounted at, the unit will be aimed for maximum coverage. However, if the unit is used for less than the maximum range, move the board up (towards 12 ft.) and walk-test the unit. **Note:** If the wall upon which the unit is mounted is not vertical, move the board up or down and walk-test the unit. If using the Long Range Lens or Barrier Lens, set the board to 12 feet on the height scale as a starting point as aiming accuracy for long range lenses can greatly affect performance.

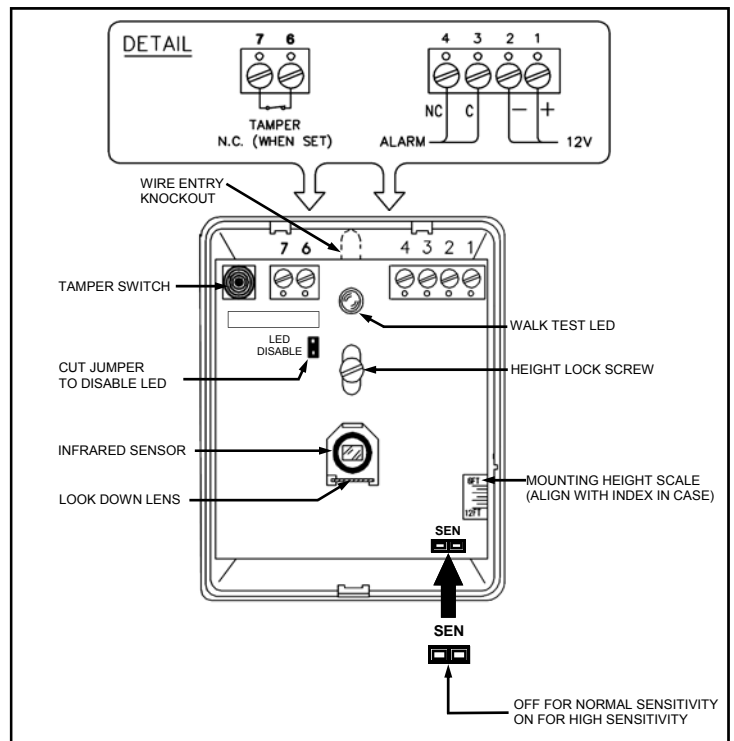

PIR1710 Circuit Board Detail

NAPCO LIMITED WARRANTY

NAPCO SECURITY SYSTEMS, INC. (NAPCO) warrants its products to be free from manufacturing defects in materials and workmanship for *thirty-six months* following the date of manufacture. NAPCO will, within said period, at its option, repair or replace any product failing to operate correctly without charge to the original purchaser or user.

This warranty shall not apply to any equipment, or any part thereof, which has been repaired by others, improperly installed, improperly used, abused, altered, damaged, subjected to acts of God, or on which any serial numbers have been altered, defaced or removed. Seller will not be responsible for any dismantling or reinstallation charges.

THERE ARE NO WARRANTIES, EXPRESS OR IMPLIED, WHICH EXTEND BEYOND THE DESCRIPTION ON THE FACE HEREOF. THERE IS NO EXPRESS OR IMPLIED WARRANTY OF MERCHANTABILITY OR A WARRANTY OF FITNESS FOR A PARTICULAR PURPOSE. ADDITIONALLY, THIS WARRANTY IS IN LIEU OF ALL OTHER OBLIGATIONS OR LIABILITIES ON THE PART OF NAPCO.

Any action for breach of warranty, including but not limited to any implied warranty of merchantability, must be brought within the six months following the end of the warranty period. IN NO CASE SHALL NAPCO BE LIABLE TO ANYONE FOR ANY CONSEQUENTIAL OR INCIDENTAL DAMAGES FOR BREACH OF THIS OR ANY OTHER WARRANTY, EXPRESS OR IMPLIED, EVEN IF THE LOSS OR DAMAGE IS CAUSED BY THE SELLER'S OWN NEGLIGENCE OR FAULT.

In case of defect, contact the security professional who installed and maintains your security system. In order to exercise the warranty, the product must be returned by the security professional, shipping costs prepaid and insured to NAPCO. After repair or replacement, NAPCO assumes the cost of returning products under warranty. NAPCO shall have no obligation under this warranty, or otherwise, if the product has been repaired by others, improperly installed, improperly used, abused, altered, damaged, subjected to accident, nuisance, flood, fire or acts of God, or on which any serial numbers have been altered, defaced or removed. NAPCO will not be responsible for any dismantling, reassembly or reinstallation charges.

This warranty contains the entire warranty. It is the sole warranty and any prior agreements or representations, whether oral or written, are either merged herein or are expressly cancelled. NAPCO neither assumes, nor

authorizes any other person purporting to act on its behalf to modify, to change, or to assume for it, any other warranty or liability concerning its products.

In no event shall NAPCO be liable for an amount in excess of NAPCO's original selling price of the product, for any loss or damage, whether direct, indirect, incidental, consequential, or otherwise arising out of any failure of the product. Seller's warranty, as hereinabove set forth, shall not be enlarged, diminished or affected by and no obligation or liability shall arise or grow out of Seller's rendering of technical advice or service in connection with Buyer's order of the goods furnished hereunder.

NAPCO RECOMMENDS THAT THE ENTIRE SYSTEM BE COMPLETELY TESTED WEEKLY.

Warning: Despite frequent testing, and due to, but not limited to, any or all of the following; criminal tampering, electrical or communications disruption, it is possible for the system to fail to perform as expected. NAPCO does not represent that the product/system may not be compromised or circumvented; or that the product or system will prevent any personal injury or property loss by burglary, robbery, fire or otherwise; nor that the product or system will in all cases provide adequate warning or protection. A properly installed and maintained alarm may only reduce risk of burglary, robbery, fire or otherwise but it is not insurance or a guarantee that these events will not occur. CONSEQUENTLY, SELLER SHALL HAVE NO LIABILITY FOR ANY PERSONAL INJURY, PROPERTY DAMAGE, OR OTHER LOSS BASED ON A CLAIM THE PRODUCT FAILED TO GIVE WARNING. Therefore, the installer should in turn advise the consumer to take any and all precautions for his or her safety including, but not limited to, fleeing the premises and calling police or fire department, in order to mitigate the possibilities of harm and/or damage.

NAPCO is not an insurer of either the property or safety of the user's family or employees, and limits its liability for any loss or damage including incidental or consequential damages to NAPCO's original selling price of the product regardless of the cause of such loss or damage.

Some states do not allow limitations on how long an implied warranty lasts or do not allow the exclusion or limitation of incidental or consequential damages, or differentiate in their treatment of limitations of liability for ordinary or gross negligence, so the above limitations or exclusions may not apply to you. This Warranty gives you specific legal rights and you may also have other rights which vary from state to state.