



HD-TVI Speed Dome

Quick Start Guide

Thank you for purchasing our product. If there are any questions, or requests, please do not hesitate to contact the dealer.

This manual applies to **HD-TVI Speed Domes**.

This manual may contain several technical incorrect places or printing errors, and the content is subject to change without notice. The updates will be added to the new version of this manual. We will readily improve or update the products or procedures described in the manual. The figures in this manual are for reference only.

DISCLAIMER STATEMENT

“Underwriters Laboratories Inc. (“UL”) has not tested the performance or reliability of the security or signaling aspects of this product. UL has only tested for fire, shock or casualty hazards as outlined in UL’s Standard(s) for Safety, UL60950-1. UL Certification does not cover the performance or reliability of the security or signaling aspects of this product. UL MAKES NO REPRESENTATIONS, WARRANTIES OR CERTIFICATIONS WHATSOEVER REGARDING THE PERFORMANCE OR RELIABILITY OF ANY SECURITY OR SIGNALING RELATED FUNCTIONS OF THIS PRODUCT.”

Regulatory Information

FCC Information

FCC compliance: This equipment has been tested and found to comply with the limits for a digital device, pursuant to part 15 of the FCC Rules. These limits are designed to provide reasonable protection against harmful interference when the equipment is operated in a commercial environment. This equipment generates, uses, and can radiate radio frequency energy and, if not installed and used in accordance with the instruction manual, may cause harmful interference to radio communications. Operation of this equipment in a residential area is likely to cause harmful interference in which case the user will be required to correct the interference at his own expense.

FCC Conditions

This device complies with part 15 of the FCC Rules. Operation is subject to the following two conditions:

1. This device may not cause harmful interference.
2. This device must accept any interference received, including interference that may cause undesired operation

EU Conformity Statement



This product and - if applicable - the supplied accessories too are marked with "CE" and comply therefore with the applicable harmonized European standards listed under the Low Voltage Directive 2006/95/EC, the EMC Directive 2004/108/EC, the

RoHS Directive 2011/65/EU.



2012/19/EU (WEEE directive): Products marked with this symbol cannot be disposed of as unsorted municipal waste in the European Union. For proper recycling, return this product to your local supplier upon the purchase of equivalent new equipment, or dispose of it at designated collection points. For more information see:

www.recyclethis.info.



2006/66/EC (battery directive): This product contains a battery that cannot be disposed of as unsorted municipal waste in the European Union. See the product documentation for specific battery information. The battery is marked with this symbol, which may include lettering to indicate cadmium (Cd), lead (Pb), or mercury (Hg). For proper recycling, return the battery to your supplier or to a designated

collection point. For more information see: www.recyclethis.info.



Safety Instruction

These instructions are intended to ensure that user can use the product correctly to avoid danger or property loss.

The precaution measure is divided into “Warnings” and “Cautions”

Warnings: Serious injury or death may occur if any of the warnings are neglected.

Cautions: Injury or equipment damage may occur if any of the cautions are neglected.

	
Warnings Follow these safeguards to prevent serious injury or death.	Cautions Follow these precautions to prevent potential injury or material damage.



Warnings

- All the electronic operation should be strictly compliance with the electrical safety regulations, fire prevention regulations and other related regulations in your local region.
- Please use the power adapter, which is provided by normal company. The standard of the power adapter is 24VAC±10% or 12VDC±10% (depending on models). The power consumption cannot be less than the required value.
- Do not connect several devices to one power adapter as adapter overload may cause over-heat or fire hazard.
- Please make sure that the power has been disconnected before you wire, install or dismantle the speed dome.
- When the product is installed on wall or ceiling, the device shall be firmly fixed.
- If smoke, odors or noise rise from the device, turn off the power at once and unplug the power cable, and then please contact the service center.
- If the product does not work properly, please contact your dealer or the nearest service center. Never attempt to disassemble the speed dome yourself. (We shall not assume any responsibility for problems caused by unauthorized repair or maintenance.)



Cautions

- Do not drop the dome or subject it to physical shock, and do not expose it to high electromagnetism radiation. Avoid the equipment installation on vibrations surface or places subject to shock (ignorance can cause equipment damage).
- Do not place the dome in extremely hot, cold, dusty or damp locations, otherwise fire or electrical shock will occur. The operating temperature should be -30°C ~ 65°C(outdoor speed dome) and -10°C ~ 50°C (indoor speed dome).
- The dome cover for indoor use shall be kept from rain and moisture.
- Exposing the equipment to direct sun light, low ventilation or heat source such as heater or radiator is forbidden (ignorance can cause fire danger).

HD-TVI Speed Dome ▪ Quick Start Guide

- Do not aim the speed dome at the sun or extra bright places. A blooming or smear may occur otherwise (which is not a malfunction however), and affecting the endurance of sensor at the same time.
- Please use the provided glove when open up the dome cover, avoid direct contact with the dome cover, because the acidic sweat of the fingers may erode the surface coating of the dome cover.
- Please use a soft and dry cloth when clean inside and outside surfaces of the dome cover, do not use alkaline detergents.
- Please keep all wrappers after unpack them for future use. In case of any failure occurred, you need to return the speed dome to the factory with the original wrapper. Transportation without the original wrapper may result in damage on the speed dome and lead to additional costs.

Table of Contents

1 Installation	6
1.1 Connecting the Cables	6
1.2 DIP Switch Settings	7
1.3 Wiring and Installation	9
1.3.1 Wiring	9
1.3.2 Installing the Bracket	9
1.3.3 Set the DIP Switch	10
1.3.4 Installing the Speed Dome	10
2 Application and Operations	12
2.1 System Application	12
2.2 Basic Operations	12
2.2.1 Configuring Patrol	13
2.2.2 Configuring Park Actions	16
3 Troubleshooting	18
3.1 Device Exceptions	18
3.2 PTZ Control Exceptions	18
3.3 Other Questions	18

1 Installation

Before you start:

Check the package contents and make sure that the device in the package is in good condition and all the assembly parts are included.

There are several ways to install the analog speed dome. The wall mounting is taken as an example below.

1.1 Connecting the Cables

Please turn the power off before connect the cables.

The cable interfaces of speed dome are shown in following figure. The cables are distinguished by different colors. The labels attached on the cables are for identification.

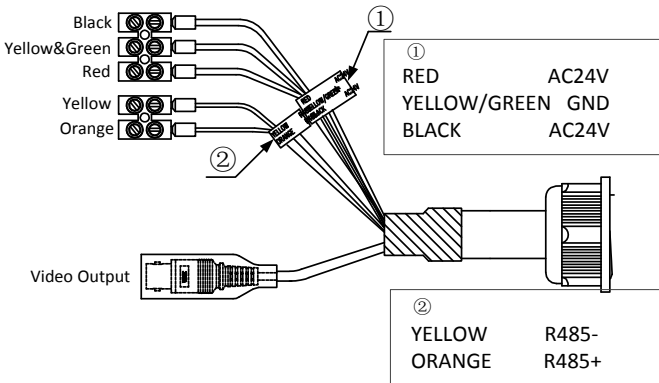

Figure 1-1 Cables of Speed Dome

Table 1-1 Cables Description

Name	Description
AC24V	Power supply
RS485+/-	485 control
VIDEO	Coaxial and analog video output

1.2 DIP Switch Settings

Two DIP switches *SW1* and *SW2* are for setting the speed dome address, baudrate, protocol, etc., with value ON=1 and OFF=0. The switch label is on the back of the SWITCH cover as shown in Figure 1-2.

Each number of the switch represents a DIP value, ranging from 1 to 8 for the lowest to highest.

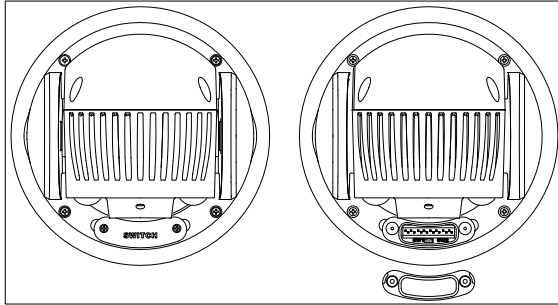

Figure 1-2 Label of DIP Switch for IR Speed Dome



Figure 1-3 Enlarged View of DIP Switch



The default dome address is 0; the default baudrate is 2400; and the default value of the 120Ω terminator is OFF.

Address Settings

The SW1 switch is used for setting the address of speed dome. You can refer to Table 1-2 for details of setting the speed dome address to a specific number.

Table 1-2 Set the Dome Address

Dome Address	1	2	3	4	5	6	7	8
0	OFF	OFF	OFF	OFF	OFF	OFF	OFF	OFF
1	ON	OFF	OFF	OFF	OFF	OFF	OFF	OFF
2	OFF	ON	OFF	OFF	OFF	OFF	OFF	OFF
3	ON	ON	OFF	OFF	OFF	OFF	OFF	OFF
-	-	-	-	-	-	-	-	-
255	ON	ON	ON	ON	ON	ON	ON	ON

Baudrate Settings

The No. 1, 2 and 3 of SW2 switch are for setting the baudrate of the speed dome, standing for 2400bps, 4800bps and 9600bps respectively. The baudrate will be set as 2400bps by default if it is out of this range. Refer to the following table:

Table 1-3 Set the Baudrate of the Dome

DIP Switch SW2-Baudrate Settings			
Baudrate	1	2	3
2400	ON	OFF	OFF
4800	OFF	ON	OFF
9600	ON	ON	OFF
19200	OFF	OFF	ON

Protocol Settings

The speed dome is self-adaptive to PELCO-D, PELCO-P and private protocol which cannot set by the DIP switches.

Communication Mode Settings

The No. 7 of SW2 switch is for setting the RS485 communication mode of the dome to simplex or half-duplex.

Table 1-4 Set Communication Mode of the Dome

DIP Switch SW2-Simplex/Half-duplex Settings	
Description	7
Simplex	OFF
Half-duplex	ON

Terminal Resistor Settings

The No. 8 of SW2 switch is used for turning on/off the 120Ω terminal resistor.

Table 1-5 Set Terminal Resistor

Switch Number	8
Description	
Turn on the resistor	OFF
Turn off the resistor	ON



The o-ring in the groove of the switch cover is for waterproof.

1.3 Wiring and Installation

There are several ways to install the speed dome. The wall mounting is taken as an example below.

1.3.1 Wiring

The survey of the actual installation environment and planning the wiring is highly recommended before the accurate deployment of the wire is implemented in order to provide a safe and steady power supply and a reasonable wiring route.

- Get familiar with the installation environment before deploying the wire, including the wiring distance, surrounding, and electromagnetic interference and so on.
- Please choose the cable with nominal voltage higher than the actual voltage, to ensure a normal running in case of unsteady voltage.
- To protect the power cable and the signal transmitting cable from human tampering, you should pay attention to the protection and reinforcement of the cables.
- When deploying the wire, please do not tighten the wire or make the wire loose.

The wiring of the speed dome should be performed by professionals.

1.3.2 Installing the Bracket

Before you start:

Wall mounting is applicable to the indoor/outdoor solid wall construction. The followings are the mandatory precondition for wall mounting:

- The wall must be thick enough to install the expansion screws.
- Please make sure that the wall is strong enough to withstand more than 8 times the weight of the dome and the mount.

Steps:

1. Check whether the type of the bracket and the number of accessories are right, as shown in the figure below.

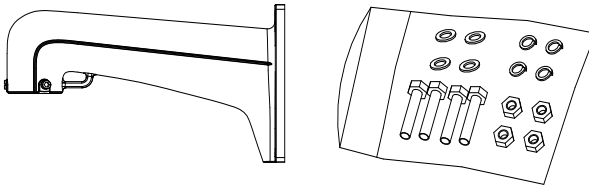

Figure 1-4 Wall Mount Bracket, Nuts and Flat Washers

2. Drill 4 screw holes in the wall according to the holes of the mount, and then insert M8 expansion screws (not supplied) into the mounting holes.

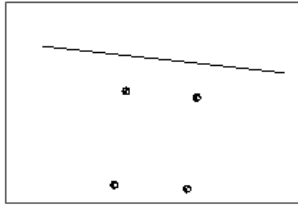

Figure 1-5 Drill Mounting Holes

3. Attach the wall mount to the wall by aligning the 4 screw holes of the mount with expansion screws on the wall.
4. Secure the wall mount with 4 hex nuts and washers.

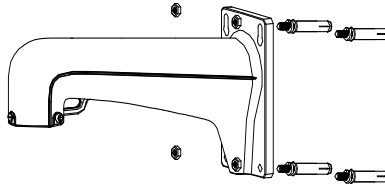

Figure 1-6 Secure the Mount

5. Install the speed dome to the mount. Please refer to *Section 1.3.4 Installing the Speed Dome* for installation details.



Follow the same instructions described above for the short-arm wall mounting. For outdoor applications, please adopt the water-proof measures. The short-arm wall mount is not recommended for outdoor applications.

1.3.3 Set the DIP Switch

Set the DIP Set the address and baudrate for the analog speed dome. The default value of DIP switch is shown below:

- ◆ **Address: 0**
- ◆ **Baudrate:2400**
- ◆ **Terminal Resistor: OFF**

Please refer to the *Section 1.2 DIP Switch Settings* for DIP switch settings.

1.3.4 Installing the Speed Dome



The sketched of installing the speed dome are for reference only.

Steps:

1. Hang the safety rope to the speed dome and then hook to the mount as shown in Figure 1-7.

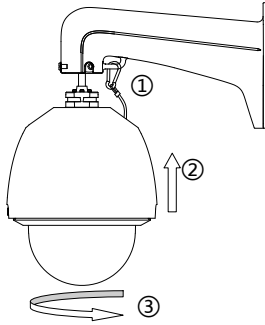

Figure 1-7 Mount the Dome

2. Route the cables of the speed dome through the wall mount.
3. Connect the corresponding video/power/RS-485 cables.
4. Install the speed dome to the mount, and secure the speed dome by rotating the speed dome clockwise.
5. Fasten the two lock screws with the Allen wrench.

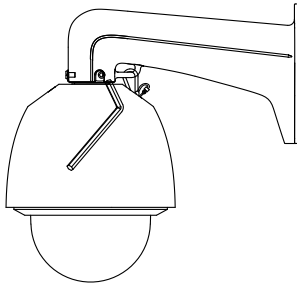

Figure 1-8 Tighten the Lock Screws

2 Application and Operations

2.1 System Application

The device can be controlled through the back-end device or control software. The back-end device includes control keyboard, DVR (Digital Video Recorder), etc., and the control software includes client software. Here we take the connection of DVR as the example.

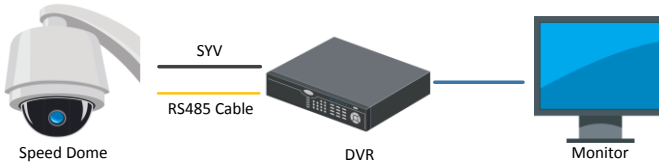

Figure 2-1 Main Menu



- If both the speed dome and the DVR support the coaxial function, the RS485 cable is not necessary.
- The HD-TVI speed dome can be connected by specific HD-TVI DVR only.

2.2 Basic Operations

Make sure the speed dome is connected properly, and the following basic operations are supported:

Panning and tilting:

Click the direction buttons to control the pan and tilt movement of the speed dome.

Zooming:

Click the **ZOOM+** and **ZOOM-** buttons to control the zooming.

Focusing:

Click the **FOCUS+** and **FOCUS-** buttons to adjust the focus.

Iris:

Click the **IRIS+** and **IRIS-** buttons to adjust the iris.

Preset control:

The speed dome supports the preset function, and the configurable preset range varies according to the control system. The system menu pops up after you call the No.95 preset

The main menu interface is shown as follows:

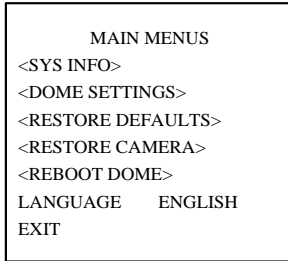

Figure 2-2 Main Menu



Refer to the user manual for the detailed instruction to set the speed dome.

2.2.1 Configuring Patrol

You can set the patrol function by the DVR and OSD menu, as well as the one-touch patrol can be realized.

- **Configuring Patrol by DVR**

Steps:

1. Enter the PTZ Control interface.

Menu>Camera>PTZ



Figure 2-3 PTZ Settings

2. Select patrol No. in the drop-down list of patrol.
3. Click the **Set** button to add key points for the patrol.

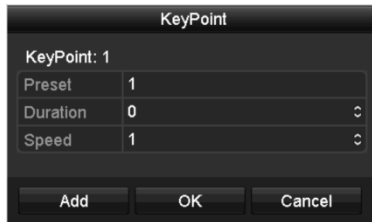

Figure 2-4 Key point Configuration

4. Configure key point parameters, such as the key point No., duration of staying for one key point and speed of patrol. The key point is corresponding to the preset. The **Key Point No.** determines the order at which the PTZ will follow while cycling through the patrol. The **Duration** refers to the time span to stay at the corresponding key point. The **Speed** defines the speed at which the PTZ will move from one key point to the next.
5. Click the **Add** button to add the next key point to the patrol, or you can click the **OK** button to save the key point to the patrol.

You can delete all the key points by clicking the **Clear** button for the selected patrol, or click the **Clear All** button to delete all the key pints for all patrols.

● **Configuring Patrol by OSD Menu**

Steps:

1. Call the preset 95 to enter the main menu and move the cursor to enter patrol configuration submenu:

MAIN MENU > DOME SETTINGS > PATROLS

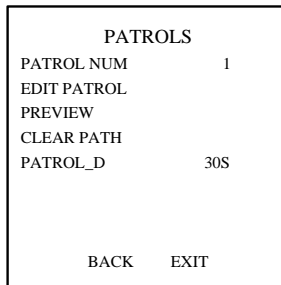

Figure 2-5 Patrol Configuration Menu

2. Choose the patrol number.
 - 1). Move the cursor to **PATROLS NUM** and click **IRIS+** to enter edit mode.
 - 2). Click the up and down direction buttons to select the number of the patrol which is to be configured.
 - 3). Click **IRIS+** again to confirm the settings and exit edit mode of this column.



Up to 8 patrols can be configured.

3. Edit the patrol.

- 1). Move the cursor to **EDIT PATROL** and click **IRIS+** to enter edit mode.

NUM	PRESET	DWELL	SPEED
1	0	6	30
2	0	6	30
3	0	6	30
4	0	6	30
5	0	6	30
6	0	6	30
7	0	6	30
DONE: OPEN		QUIT:CLOSE	

Figure 2-6 Edit the Patrol

- 2). Click up/down direction buttons to choose the number and locate the preset to be edited.
 3). Click left/right direction buttons to position the cursor to the column of **PRESET**, **DWELL** and **SPEED**. You can click the up/down direction buttons to set the value of preset number, dwell time and patrol speed.



The presets you set for a patrol should be the ones that have been pre-defined by users. The dwell time (5-800 seconds selectable) is the time that the speed dome stays on a certain preset; the patrol speed (level 1-40 selectable) is the scanning speed the speed dome switching between the presets.

- 4). Follow the above steps to define the other presets for the selected patrol. You can configure up to 32 presets in sequence for a patrol. Press **IRIS+** to save the new settings or press **IRIS-** to cancel and return to the previous menu.
4. Call the defined patrol.
 Back to the live view interface after you finish editing the patrol, and call the special presets to call the defined patrol. The presets 35~38 stand for patrol 1~4 and presets 102~105 stand for patrol 5~8.

● **Calling Quick Patrol**

The dome starts patrol from the predefined preset 1 to preset 32 in order after the park time. The undefined preset will be skipped.

Steps:

1. Set the preset 1~32 by DVR or OSD menu.
2. Call the preset 46 to start the quick patrol.

2.2.2 Configuring Park Actions

Purpose:

For some certain model of the speed dome, it can be configured to start a predefined park action (scan, preset, patrol and etc.) automatically after a period of inactivity (park time).

● Configuring Park Actions by DVR

Steps:

1. Click the button **PTZ** in the lower-right corner of the PTZ setting interface;
Menu>Camera>PTZ
2. Click the  button to show the one-touch function of the PTZ control.



Figure 2-7 PTZ Panel - One-touch

3. There are 3 one-touch park types selectable, click the corresponding button to activate the park action.

Park (Quick Patrol): The dome starts patrol from the predefined preset 1 to preset 32 in order after the park time. The undefined preset will be skipped.

Park (Patrol 1): The dome starts move according to the predefined patrol 1 path after the park time.

Park (Preset 1): The dome moves to the predefined preset 1 location after the park time.



The park time can only be set through the speed dome configuration interface, by default the value is 5s.

4. Click the button again to inactivate it.

● Configuring Park Actions by OSD Menu

Steps:

1. Call the preset 95 to enter the main menu and move the cursor to enter motion parameters setting submenu:
MAIN MENU > DOME SETTINGS > MOTION PARAMETER

MOTION	
AUTO FLIP	ON
PROPORTIONAL PAN	ON
PARK TIME	5
PARK ACT	NONE
SCAN SPEED	28
IMAGE FREEZE	OFF
DOME SPEED	6
BACK	EXIT

Figure 2-8 PTZ Configuration

2. Move the cursor to the **PARK TIME**, and set the value in the range from 5 to 720 seconds.
3. Move the cursor to the **PARK ACT**, and the action can be set as preset 1-8, pattern 1-5, patrol 1-10, pan scan, tilt scan, random scan, frame scan, panoramic scan, day mode, night mode, patrol-d or none.



If no control signal is received after the park time under the following circumstances, no park actions will be performed: in the process of performing dome actions by calling special presets.

3 Troubleshooting

3.1 Device Exceptions

Question

Why does the speed dome fail to start or repeatedly reboot? Why does the speed dome restart intermittently when controlling PTZ, calling presets or turning on the infrared lights of the IR dome at night?

Answer

- Check the supply voltage of the dome. Ensure the supply voltage to meet the power requirements of the speed dome. The nearest power supply is recommended.
- Check whether the diameter of the power wire meet the standards.

3.2 PTZ Control Exceptions

Question

The speed dome cannot do PTZ control but can do zoom control.

Answer

- For the 5 inch speed dome, you need to remove the protective sticker and foam of the camera module by opening the bubble, correctly install the speed dome again and then wire up.
- For IR speed dome, please remove the protective sticker and then wire up.

Question

Neither zoom control nor PTZ control is available for the speed dome.

Answer

- Check the supply voltage of the dome. Ensure the supply voltage to meet the power requirements of the speed dome. The nearest power supply is recommended.
- Check whether the diameter of the power wire meet the standards.

3.3 Other Questions

Question

The preview image of the speed dome is not clear.

Answer

- Please check whether the protective film of the bubble has been removed.
- Please check whether there are foreign objects on the bubble or the lens.
- Please check where there are obstructions such as spider web nearby.
- Open the bubble and check whether the lens cover has been removed.
- Restore the device to the default settings. Call the preset 95 to enter the OSD menu and select the **RESTORE CAMERA**.

Question

For the IR speed dome, the image is abnormal white when the IR light is turned on in the night.

Answer

- Please check whether there are obstructions near the lens, e.g. wall, leaf, spider web, cables, etc., which will cause the over-exposure due to the IR light reflection. Clear the obstructions if necessary.

Question

The speed dome cannot focus when working in the indoor condition.

Answer

- Please restore the device to the default to exclude the factor of incorrect configuration.
- Reduce the minimum focusing distance of the device by configuring the image settings through the OSD menu.